



VERIGA®

SINCE 1922

www.veriga-lesce.com



VERIGA *snow*





VERIGAsnow comprises tyre chains for professional and occasional use - from cars, off-road and delivery vehicles, buses, trucks, tractors to all other work machines. Our snow tyre chains are the accessories that provide you with even more traction and a safer ride on snowy and icy terrain. We are one of the world's leading manufacturers of snow chains, boasting a long tradition, quality workmanship and long product life.



A line of products developed for countries in which the use of »toothed« chains is allowed on roads. CAM locking system enables fast and easy assembly.



A line of high-quality products with long service life. Thanks to innovative design, strongest material and manufacturing process.



VERIGAtpc is a programme of protective tyre chains intended for heavy working machines in mines, quarries and landfills, where the main purpose of the chains is to protect the tyre. This niche represents an ever-increasing sales share, and potential buyers come from all over the world (Europe, South and North America, Asia, Australia,...).



Forests cover 31 % of the global landscape, and in Europe alone, that number rises to approximately 40 %. To this end, we have developed a wide range of products intended for general and professional use in forestry. With forestry being practically a year-round occupation and not as seasonal as the snow programme, it represents great potential. The VERIGAforest programme is further classified into the GreenTRACK line, represented by tracks for mobile machinery, a line of tyre chains for tractors and similar machinery, and a line of choker chains and similar logging supplies, designed for harvesting wood. All products from the VERIGAforest programme are distinguished by high-quality craftsmanship and treatment, providing a long service life.



GreenTRACK tracks for forestry machinery, with stronger traction on different types of terrain and for tyre protection. A special feature of the GreenTRACK products is heat treatment, which provides an equal hardness also on welding links.



The sport programme is a carefully thought-out additional range developed under the watchful eye of our professional associates. We were the first to introduce leisure crampons to the world. Due to extremely positive feedback from our satisfied users, we began to focus more and more resources and marketing activities on the recognition of VERIGAsport brand with the ultimate goal and wish: to get closer to our end users.

USE OF CHAINS IN EUROPE

- Legal obligation to carry chains
- Obligation to carry chains in winter conditions

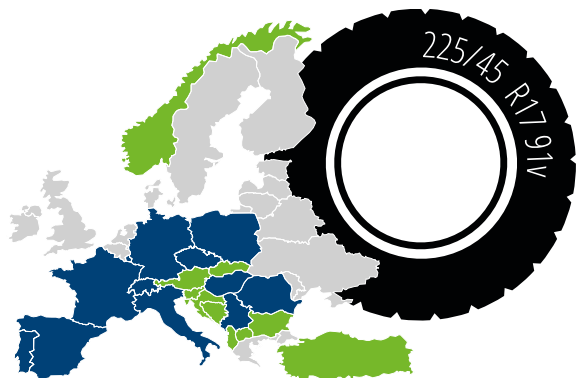

HINTS FOR CHOOSING CHAINS

What does the labeling on your tyres mean?

On the side of your tyre you can find a label of the tyre type: **225/45 R 17 91V**

Example:

- 225:** Tyre width in mm
- 45:** Aspect ratio between the width and the height in %
- R:** Tyre design – Radial tyre
- 17:** Rim diameter in inches
- 91:** Load index
- V:** Velocity symbol for the maximum allowed highspeed

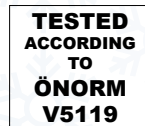

SNOW CHAINS FOR **PASSENGER CARS**

6



SNOW CHAINS FOR **SUVS, 4x4S AND CROSSOVERS**

12



SNOW CHAINS FOR **TRUCKS - PremiumLINE**



17



SNOW CHAINS FOR **TRUCKS AND BUSES**

22

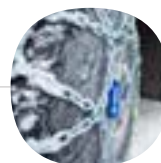

SNOW CHAINS FOR **TRUCKS AND BUSES - NordicLINE**

28



SNOW CHAINS FOR **ATV, FORKLIFTS**

33



SNOW CHAINS FOR **TRACTORS AND HEAVY MACHINERY - PremiumLINE**



38



SNOW CHAINS FOR **TRACTORS AND HEAVY MACHINERY**

44



LASHING CHAIN SYSTEMS

48



SPARE PARTS

54



VERIGA LESCE

The Veriga factory was established in 1922. The production programme included screws, forgings, heavy anchor chains, forestry towing chains, transport chains for mining, and various chains by metre, from thickness of 1 mm up to 100 mm. Later, the production expanded onto snow chains and protection chains for tractors and heavy machinery, as well as snow chains for automobiles. In 1992 the RIVAL COMPACT chain was created, patented and certified. It remains in the production of the company to this day.

Such a production programme combined with the quality of products placed Veriga among the largest manufacturers in the European and global markets. This is why the factory also manufactured chains for other renowned brands of chains. In those times, Veriga employed over 1,500 workers. In 1998, the company went through a privatisation process and was named into VERIGA K.F., d.o.o..

NOWADAYS, THE PRODUCTION PROGRAMME CONTAINS:

- Snow chains for cars, light delivery vehicles, 4x4s, lorries, tractors, and heavy machinery;
- Forestry chains for tractors and heavy machinery chains for wood towing;
- Tracks for forestry machinery;
- Protective chains for heavy machinery;
- Walking crampons for shoes and other sports equipment.

The products are sold both on the domestic and global markets. With every passing year, Veriga is increasingly successful at competing with the largest global manufacturers of chains, while the company's own brand VERIGA is also getting more and more recognition at the same time.





TOGETHER TOP

"Together to the top" is our slogan and everyday motivation. Veriga is located in Slovenia, where we are proud to highlight the quality experience of a small country rich with natural wealth. We are proud of our small country because in the end it is about quality not quantity. The same can be said for our production strategy and that's one of the many reasons it gives us a competitive advantage.

The company's vision is to become one of the three largest manufacturers of tyre chains in the world and find a suitable cover for each tyre, so we are constantly developing new products and improving existing products in terms of user-friendliness, customer support and care for our environment. Our mission is to constantly improve the quality of products and bring them closer to the user, with the aim of providing a comprehensive and quality solution. We focus on smaller serial products, where we achieve exceptional added value. In this regard we can mention custom made products exclusively for the needs of our customers.

The company's strategy is to consolidate the brand and its visibility in the market. Despite the increasingly mild winters, we found new market niches and broke into markets where snow is present all year round, and markets where a warm winter does not mean less snow. For this purpose, we also spend a lot of time and investments on the development of sports equipment.

As a significant part of our sales programme is intended for professional use, we have developed the sports segment with the aim of approaching end users. By selling chains for passenger cars, we ensure the safety of people in cars, and by developing anti-slip crampons, we ensure the safety of our customers.

As the market is constantly evolving and new technologies force us to improve continuously, a large part of the resources is devoted to research and development in all areas of the company. We are looking for new input materials, new heat treatment options for maximum product life and new technology for the production process.

In all strategic plans, one of the most important is, of course, employee training, so we are constantly investing in seminars, trainings, ensuring our presence on social networks and often attend fairs around the world.

The company exports to more than 61 countries, and the share of exports is over 90%.



SNOW CHAINS FOR **PASSENGER CARS**





CODE	SG9	SG7	PC9	PC12	STC	VCS	TA	TS
MODEL	STOP&GO CAR	STOP&GO 7	PRO COMPACT 9	PRO COMPACT 12	STARE RING CAR	VERIGA CAR SOCK	TRACTIVA AUTO	TRACTIVA SPORT
RECOMMENDED FOR							 	
MAXIMUMSPACE AT THE INNER SIDE OF THE TYRE (MM)	9	7	9	12	12	7	/	/
SUITABLE FOR LOW PROFILE TYRES	✓	✓	✓			✓	✓	✓
STOP&GO AUTOMATIC TIGHTENING AND CENTRING	✓	✓					✓	✓
AUTO-LOCKING TENSIONING SYSTEM			✓	✓	✓			
EASE OF FITTING	**** ***** 9	**** ***** 9	**** ***** 9	**** ***** 9	**** ***** 9	**** ***** 8	***** ***** 10	***** ***** 10
TRACTION	**** ***** 9	**** ***** 9	**** ***** 9	***** ***** 10	***** ***** 10	**** ***** 8	***** ***** 10	**** ***** 9
DRIVING COMFORT	**** ***** 9	***** ***** 10	**** ***** 9	**** ***** 8	**** ***** 8	***** ***** 10	**** ***** 9	***** ***** 10

STOP&GO CAR

SG9



STOP&GO 7

SG7



9 mm chain with automatic tensioning and centring of the chain. One patented self-tensioning and self-centring "STOP&GO" devices. Stopping the vehicle and tensioning the chain is not required.

- Approved in accordance with the ON V5117 and the new European standard EN16662-1.
- Running surface in rhomboid shape made of special alloy steel, with "D" profile links for safe grip on snow and ice.
- High quality heat treatment – carburising.
- Ergonomic and colour-coded parts with easy to follow fitting instructions and plastic gloves for a fast, easy and clean fitting.

Supplied in a handy and elegant semi-rigid carrying case.
Packaging: 1 pair.

	D [mm]	3
	H [mm]	9

- EN 16662-1
-
- 9 mm
- LOW PROFILE
- 3 mm
- STOP n'GO
- TESTED ACCORDING TO ONORM V5117
- CONFORME A D.M. 10.5.2011 UNI 11313

Chain with an inner tyre clearance of only 7 mm. Designed for cars where a lack of clearance makes it impossible to fit regular snow chains. Made of special twisted chain ensuring optimal performance. One patented self-tensioning and self-centring "STOP&GO" device.

- Approved in accordance with the ON V5117 and the new European standard EN16662-1.
- Running surface in rhomboid shape made of special alloy steel with twisted links for safe grip on snow and ice.
- High quality heat treatment – carburising.
- Ergonomic and colour-coded parts with easy to follow fitting instructions and plastic gloves for a fast, easy and clean fitting.

Supplied in a handy and elegant semi-rigid carrying case.
Packaging: 1 pair.

	D [mm]	3
	H [mm]	7

- EN 16662-1
-
- 7 mm
- LOW PROFILE
- 3 mm
- STOP n'GO
- TESTED ACCORDING TO ONORM V5117
- CONFORME A D.M. 10.5.2011 UNI 11313

PRO COMPACT 9

PC9



9 mm chain with manual tensioning.
Chain of excellent quality and durability, reliable even in emergency situations.

- Approved in accordance with the ON V5117 and the new European standard EN16662-1.
- Running surface in rhomboid shape, made of special alloy steel, with "D" profile links for safe grip on snow and ice.
- High quality heat treatment – carburising.
- Auto-locking device.
- Ergonomic and colour-coded parts with easy to follow fitting instructions and plastic gloves for a fast, easy and clean fitting.
- Polymeric tensioning chain stopper helps to preserve the rim.

Supplied in a handy and elegant semi-rigid carrying case with velcro for safer storage in the boot.
 Packaging: 1 pair.

	D [mm]	3
	H [mm]	9



PRO COMPACT 12

PC12



12 mm chain with manual tensioning.
Suitable for continuous driving on icy and snowy roads.

- Approved in accordance with the ON V5117 and the new European standard EN16662-1.
- Running surface in rhomboid shape, made of special alloy steel, with "D" profile links for safe grip on snow and ice.
- High quality heat treatment – carburising.
- Auto-locking device.
- Ergonomic and colour-coded parts with easy to follow fitting instructions and plastic gloves for a fast, easy and clean fitting.
- Polymeric tensioning chain stopper helps to preserve the rim.

Supplied in a handy and elegant semi-rigid carrying case with velcro for safer storage in the boot.
 Packaging: 1 pair.

	D [mm]	3,5
	H [mm]	12



STARE RING CAR

STC



VERIGA CAR SOCK

VCS

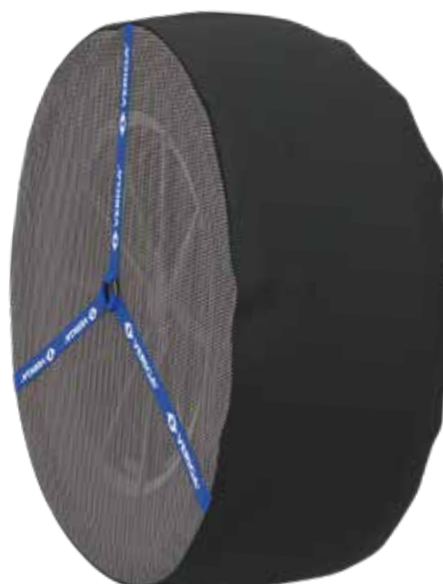

Easy to fit 12 mm chain, ideal for vehicles with limited inner clearance. The special internal rigid arch makes fitting and demounting the chain very simple. The chain can be fitted and dismounted without moving the car.

- Approved in accordance with the ON V5117 and the new European standard EN16662-1.
- Running surface in rhomboid shape, made of special alloy steel, with "D" profile links for safe grip on snow and ice.
- High quality heat treatment – carburising.
- Ergonomic and colour-coded parts with easy to follow fitting instructions and plastic gloves for a fast, easy and clean fitting.

Supplied in a handy and elegant semi-rigid carrying case.
Packaging: 1 pair.

	D [mm]	3,5
	H [mm]	12

Anti-slip tyre cover made of special fabric.

- Ideal for driving on snowy and icy roads.
- Running surface made of special, high durability fabric.
- Simple and easy installation and removal.
- Approved in accordance with the ON 5121 and the new European standard EN16662-1.
- The Car Sock often replaces the use of classic snow chains, where they are prescribed by law (standard EN 16662-1). But not in all countries. In Slovenia Sock is legally permitted.

Supplied in a handy fabric bag.
Packaging: 1 pair.



12 mm



3,5 mm

AUTO LOCK

TESTED ACCORDING TO ONDRM V5117

CONFORME A.D.M. 10.5.2011 UNI 11313

EN 16662-1



7 mm

TESTED ACCORDING TO ONDRM V5121

LOW PROFILE

EN 16662-1

CONFORME A.D.M. 10.5.2011 UNI 11313

CONFORME A.D.M. 10.5.2011 UNI 11313

TRACTIVA AUTO

TA

NEW



With a clearance of 16 mm on the tyre thread, Tractiva Auto is the most robust and resilient chain of the whole Tractiva line.

- Approved in accordance with the ON V5117 and the new European standard EN16662-1.
- Cross square chain configuration.
- Case hardened chain pattern with rubber tensioners and traction bars.
- Polyurethane guides with carbide spikes .
- Tractiva smart wheel fitting system.
- Bolt kits and instruction book.

Nylon bag and outer carton box.

Packaging: 1 pair.

	D [mm]	4
	H [mm]	16



TRACTIVA SPORT

TS

NEW



With an encumbrance of only 10 mm on the tyre thread, Tractiva Sport is the lightest and more compact chain in Tractiva range.

- Approved in accordance with the ON V5117 and the new European standard EN16662-1.
- Cross square chain configuration.
- Case hardened chain pattern with rubber tensioners and traction bars.
- Polyurethane guides with carbide spikes.
- Tractiva smart wheel fitting system.
- Bolt kits and instruction book.

Nylon bag and outer carton box.

Packaging: 1 pair.



VIDEO

	D [mm]	3
	H [mm]	10



SNOW CHAINS FOR **SUVs, 4x4s and CROSSOVERS**





CODE	SG13	PRF16	PN16	STS	TU
MODEL	STOP&GO SUV 13	PROFI FORST	PROFESSIONAL NT 16	STARE RING SUV	TRACTIVA SUV
RECOMMENDED FOR					
MAXIMUM SPACE AT THE INNERSIDE OF THE TYRE (MM)	13	16	16	16	/
EXTRA GRIP		✓			
STOP&GO AUTOMATIC TIGHTENING AND CENTRING	✓				✓
AUTO-LOCKING TENSIONING SYSTEM			✓	✓	
EASE OF FITTING	**** ***** 9	**** ***** 8	**** ***** 8	**** ***** 8	**** ***** 10
TRACTION	***** ***** 10	***** ***** 10	***** ***** 10	***** ***** 10	***** ***** 10
DRIVING COMFORT	**** ***** 8	**** ***** 8	**** ***** 8	**** ***** 8	**** ***** 9

STOP&GO SUV 13

SG13



13 mm chain with automatic tensioning and centring of the chain, created for SUVs, mobile homes and off-road vehicles. Two patented self-tensioning and self-centring "STOP&GO" devices. Stopping the vehicle and tensioning the chain is not required.

- Approved in accordance with the ON V5117 and the new European standard EN16662-1.
- Running surface in rhomboid shape, made of special alloy steel, with "D" profile links for safe grip on snow and ice.
- High quality heat treatment – carburising.
- Ergonomic and colour-coded parts with easy to follow fitting instructions and plastic gloves for a fast, easy and clean fitting.

Supplied in a handy and elegant semi-rigid carrying case.
Packaging: 1 pair.

	D [mm]	3,7
	D1 [mm]	4,2
	H [mm]	13



PROFI FORST

PRF16



16 mm off-road vehicle chain, professional and universal, also suitable for forest terrains. Perfect solution for the most demanding conditions.

- Approved in accordance with the ON V5117 and the new European standard EN16662-1.
- Running surface in thick net made of special alloy steel, with 4,5 mm thick "D" profile links.
- High quality heat treatment – carburising.
- Ideal for use on mud, rocks, branches and roots, snow and ice.
- Excellent fit and comfort while driving.
- Made for terrain forestry, hunting, police, firefighters and military vehicles.

Supplied in a durable bag made of persistent material.
Packaging: 1 pair.

	D [mm]	4,5
	H [mm]	16



PROFESSIONAL NT 16

PN16



16 mm quick fitting chain, ideal for vans, mobile homes, light delivery vehicles and 4x4s. Ideal also for utility vehicles and professional performance.

- Approved in accordance with the ON V5117 and the new European standard EN16662-1.
- Running surface in rhomboid shape, made of special alloy steel, with "D" profile links for safe grip on snow and ice.
- High quality heat treatment – carburising.
- Auto-locking device.
- Ergonomic and colour-coded parts with easy to follow fitting instructions and plastic gloves for a fast, easy and clean fitting.

Supplied in a handy and elegant semi-rigid carrying case with velcro for safer storage in the boot.

Packaging: 1 pair.

	D [mm]	4,5
	H [mm]	16



STARE RING SUV

STS



16 mm chain, simplified installation, ideal for vehicles where space is severely limited. Simple installation and removal due to a rigid arch which enables installation and removal without moving the vehicle.

- Approved in accordance with the ON V5117 and the new European standard EN16662-1.
- Running surface in rhomboid shape made of special alloy steel with "D" profile links for safe grip on snow and ice.
- High quality heat treatment – carburising.
- Ergonomic and colour-coded parts with easy to follow fitting instructions and plastic gloves for a fast, easy and clean fitting.

Supplied in a handy handbag.

Packaging: 1 pair.

	D [mm]	4,5
	H [mm]	16

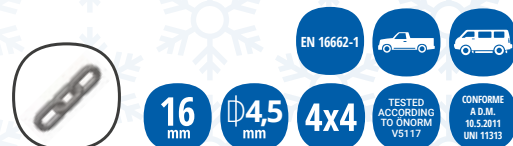



TRACTIVA SUV

TU

NEW



With a link height of 16 mm, the Tractiva SUV is built for the most extreme conditions. Additionally, the D-profile links will give your SUV the extra grip it needs to battle snow and ice.

- Approved in accordance with the ON V5117 and the new European standard EN16662-1.
- Innovative tread mesh construction.
- Case-hardened chain parts with rubber tensioners and special transverse traction bars.
- Polyurethane guides with carbide spikes.
- Tractiva smart wheel fitting system.
- Screw set and user guide.

Nylon bag and outer carton box.

Packaging: 1 pair.



VIDEO

	D [mm]	4
	H [mm]	16



16 mm

34 mm

4x4

EN 16662-1

TESTED ACCORDING TO ONDRM V5117

CONFORME A.D.M. 10.5.2011 UNI 11313











Premium**LINE**

SNOW CHAINS FOR **TRUCKS**

VERIGA  SNOW





CODE	PE	PS	PI	MT	MD
MODEL	PROFI EXTREME	PROFI SUPER	PROFI	MASTER TRUCK	MASTER TRUCK DOUBLE
RECOMMENDED FOR		  		  	
REINFORCED LINKS	✓	✓			
SUITABLE FOR USE ON FRONT WHEELS	✓	✓	✓	✓	
POSSIBILITY OF USE ON BOTH SIDES		✓	✓	✓	✓
USE ON DUAL WHEELS					✓
EASE OF FITTING	**** ***** 9	**** ***** 9	**** ***** 9	**** ***** 9	**** *** 7
TRACTION	***** ***** 10	***** ***** 10	***** ***** 10	**** **** 8	**** ***** 9
DRIVING COMFORT	**** **** 8	**** ***** 9	***** ***** 10	**** ***** 9	**** ***** 9
SIDE GRIP	**** ***** 9	**** ***** 9	**** ***** 9	**** **** 8	**** ***** 9
WEAR RESISTANCE	**** ***** 9	**** ***** 9	**** ***** 9	**** **** 8	**** **** 8

PROFI EXTREME

PE

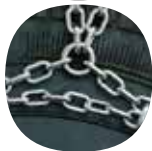

PROFI SUPER

PS



VERIGA SNOW

Cargo vehicle chains, intended for wood transportation and winter services.

- Approved in accordance with the standard ON V5119.
- Chains are net woven and made of special alloy steel for a safer grip on snow and ice.
- Chain links made of "D" profile wire with a thickness of 7 mm.
- In the desire to wear the edge of the tyre less, the connections to the tread part of the chain are made of chain of a round profile of 7 mm.
- With reinforced links and additional welded plates for constant use on snow and ice.
- High quality heat treatment –carburising.
- Operating instructions enable fast assembly.

Supplied in a durable bag made of persistent material.
Packaging: 1/2 pair in bag.

	D [mm]	7
	H [mm]	34



Cargo vehicle chains, intended for wood transportation and winter services.

- Approved in accordance with the standard ON V5119.
- Chains are net woven and made of special alloy steel for a safer grip on snow and ice.
- Chain links made of "D" profile wire with a thickness of 7 mm.
- In the desire to wear the edge of the tyre less, the connections to the tread part of the chain are made of chain of a round profile of 7 mm.
- With reinforced links, for constant use on snow and ice.
- Use on both sides for longer life.
- High quality heat treatment –carburising.
- Operating instructions enable fast assembly.

Supplied in a durable bag made of persistent material.
Packaging: 1/2 pair in bag.

	D [mm]	7
	H [mm]	27





PROFI

PI



Chain for trucks, with an asymmetric net for a better grip. Ideal for a longer, uninterrupted use.

- Approved in accordance with the standard ON V5119.
- In the desire to wear the edge of the tyre less, the connections to the tread part of the chain are made of chain of a round profile of 7 mm.
- Running surface in rhomboid shape made of special alloy steel, with "D" profile links for safe grip on snow and ice.
- High quality heat treatment – carburising.
- Operating instructions enable fast assembly.
- Chains can be used on both sides which significantly improves durability.

Supplied in a durable bag made of persistent material. Packaging: ½ pair per bag.

	D [mm]	7
	H [mm]	27



MASTER TRUCK

MT



Chain for trucks, with an asymmetric net for a better grip. Ideal for a longer, uninterrupted use.

- Approved in accordance with the standard ON V5119.
- Link thickness of 5,5 mm, 7 mm or 8 mm.
- Running surface in rhomboid shape made of special alloy steel, with "D" profile links for safe grip on snow and ice.
- High quality heat treatment – carburising.
- Operating instructions enable fast assembly.

In a bag made of durable fabric.

Packaging: 1 pair per bag or ½ pair per bag depending on the size.

	D [mm]	5,5	7	8
	H [mm]	20	27	30



MASTER TRUCK DOUBLE

MD



For dual wheels, with asymmetric net. Ideal for longer, uninterrupted use.

- Approved in accordance with the standard ON V5119.
- Link thickness of 4,5 mm, 5,5 mm, 7 mm or 8 mm.
- Running surface in asymmetric rhomboid shape made of special alloy steel, with "D" profile links for safe grip on snow and ice.
- High quality heat treatment – carburising.
- Operating instructions enable fast assembly.

In a bag made of durable fabric.

Packaging: 1 pair per bag or ½ pair per bag depending on the size.

	D [mm]	4,5	5,5	7	8
	H [mm]	16	20	27	30



SNOW CHAINS FOR **TRUCKS AND BUSES**

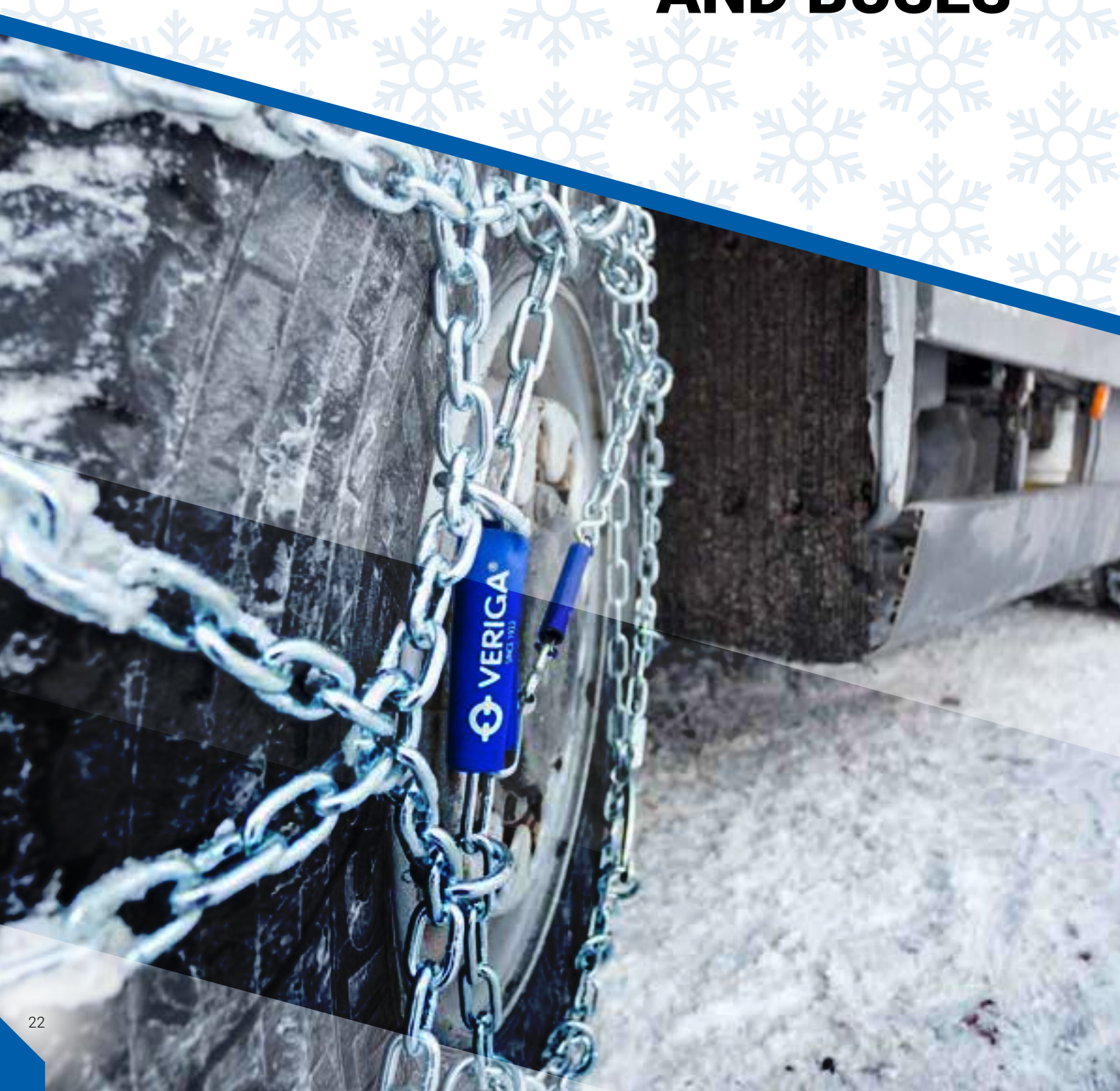



CODE			AS	A	SST	STR	SRB	MB
MODEL	TRACTIVA CARGO	TRACTIVA PRO	ARKTIK SUPER	ARKTIK	S-STOP	STREME	STARE RING BUS	MAX BUS
RECOMMENDED FOR								
REINFORCED LINKS			✓					
SUITABLE FOR USE ON FRONT WHEELS	✓	✓	✓	✓			✓	✓
POSSIBILITY OF USE ON BOTH SIDES			✓	✓				
USE ON DUAL WHEELS								
EASE OF FITTING	***** ***** 10	***** ***** 10	**** **** 8	**** **** 8	***** ***** 10	***** ***** 10	***** ***** 10	**** ***** 9
TRACTION	***** ***** 10	***** ***** 10	**** ***** 9	**** **** 8	*** **** 7	*** **** 7	**** **** 8	**** **** 8
DRIVING COMFORT	**** ***** 9	***** ***** 10	**** **** 8	**** ***** 9	**** **** 8	*** **** 7	**** ***** 9	**** ***** 9
SIDE GRIP	***** ***** 10	***** ***** 10	**** ***** 9	**** ***** 9	**** **** 8	*** **** 7	**** ***** 9	**** ***** 9
WEAR RESISTANCE	**** ***** 9	**** ***** 9	**** ***** 9	**** **** 8	**** **** 8	*** **** 7	**** **** 8	**** **** 8

TRACTIVA CARGO



Cargo vehicle chain with fast assembly. Equipped with a D profile chain link of 6 mm, Tractiva CARGO is a solution with the fastest mounting for all trucks. Fitted from the outside of the tyre, with 4 arms configuration and steel carbon spikes on 4 plastic guides. Tractiva Cargo is both an emergency and a long run chain.

- Tested according ON V5119;
- Innovative patented hooking solution.
- Case hardened chain with metal grip bars and shortening screws for regulation.
- Polyurethane guides with carbon spikes.
- Operating instructions enable fast assembly.

Packing: Nylon bag for each half of the pair.

	D [mm]	6
	H [mm]	22



TRACTIVA PRO



Equipped with a D profile chain link of 6 mm, Tractiva Pro is the professional solution with a maximum grip thanks to the 6 arms configuration and carbone spikes on 6 plastic guides. Suitable for the most exigent drivers, for international routes, for any occasion where a fast mounting and dismounting is a must.

- Tested according ON V5119.
- Innovative patented hooking solution.
- Case hardened chain with metal grip bars and shortening screws for regulation.
- Polyurethane guides with carbon spikes.
- Operating instructions enable fast assembly.

Packing: Nylon bag for each half of the pair.

	D [mm]	6
	H [mm]	22



ARKTIK SUPER

AS



Truck chain with reinforced links. Reinforced for intensive use.

- Approved in accordance with the standard ON V5119.
- Link thickness of 4.5 mm, 5.5 mm or 7 mm.
- Running surface in rhomboid shape made of special alloy steel, with "D" profile links for safe grip on snow and ice.
- High quality heat treatment – carburising.
- Reinforced with additional "D" profile links for better grip and durability.
- Operating instructions enable fast assembly.
- Chains can be used on both sides which significantly improves durability.

In a bag made of durable fabric.

Packaging: 1 pair per bag or ½ pair per bag depending on the size.

	D [mm]	4,5	5,5	7
	H [mm]	16	20	27



TESTED
ACCORDING
TO ONORM
V5119

ARKTIK

A



Truck chain. Strong and reliable.

- Approved in accordance with the standard ON V5119.
- Link thickness of 4.5 mm, 5.5 mm or 7 mm.
- Running surface in rhomboid shape made of special alloy steel, with "D" profile links for safe grip on snow and ice.
- High quality heat treatment – carburising.
- Operating instructions enable fast assembly.

In a bag made of durable fabric.

Packaging: 1 pair per bag or ½ pair per bag depending on the size.

	D [mm]	4,5	5,5	7
	H [mm]	16	20	27



TESTED
ACCORDING
TO ONORM
V5119

S-STOP

SST



Chain with straps, locking with belt and tensioner. Simple installation, does not damage the rims. Quick installation without moving the vehicle.

- Link thickness of 5,7 mm or 7 mm.
- Net woven running surface made of special alloy steel, with "D" profile links for safe grip on snow and ice.
- High quality heat treatment – carburising.
- Useful for vehicles with holes in their rims.
- Due to the strap and tensioner installation system, the fitting and removal are quicker and simpler.
- Operating instructions enable fast assembly.

To ensure optimal functioning, we recommend the installation of at least three elements onto each of the drive wheels.

In a bag made of durable fabric.
Packaging: 2 pieces per bag.

	D [mm]	5,7	7
	H [mm]	20	27



STREME

STR

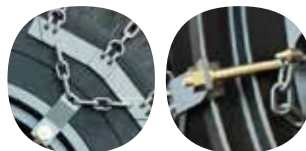

Chain with stirrups. Classic safety mechanism, locking with nuts and bolts. Quick installation without moving the vehicle.

- Link thickness of 5,7 mm, 6,4 mm or 7 mm.
- Running surface in transverse shape made of special alloy steel, with "D" profile links for safe grip on snow and ice.
- High quality heat treatment – carburising.
- Useful for all vehicles with holes in their rims.
- Classic locking system with nuts and bolts.
- Operating instructions enable fast assembly.

To ensure optimal functioning, we recommend the installation of at least three elements onto each of the drive wheels.

In a bag made of durable fabric.
Packaging: 6 pieces per bag.

	D [mm]	5,7	6,4	7
	H [mm]	20	24	27



STARE RING BUS

SRB



Chain with simplified installation, designed for buses. With a rigid arch and no inner connections, for simple installation and removal exclusively from the outer part of the wheel.

- Approved in accordance with the standard ON V5119.
- Link thickness of 5,5 mm. Takes 20 mm of space at the inner side.
- Running surface in rhomboid shape made of special alloy steel, with "D" profile links for safe grip on snow and ice.
- High quality heat treatment – carburising.
- Ergonomic and colour-coded parts with operating instructions enable fast assembly.

Packaging: 1 pair in a handy fabric bag.

	D [mm]	5,5
	H [mm]	20

	OPTIONAL:
	Gloves for mounting Universal size = L - XL Length = 60 cm



MAX BUS

MB



Chain for buses, trucks and light delivery vehicles. Quick installation without moving the vehicle.

- Approved in accordance with the standard ON V5119.
- Link thickness of 5,5 mm or 7 mm.
- Running surface in rhomboid shape made of special alloy steel, with "D" profile links for safe grip on snow and ice.
- High quality heat treatment – carburising.
- Spring locking system, constant tensioning.
- Heat treatment of tensioning chain ensures its durability.
- Ergonomic and colour-coded parts with operating instructions enable fast assembly.

Packaging: 1 pair in a handy fabric bag.

	D [mm]	5,5	7
	H [mm]	20	27

	OPTIONAL:
	Gloves for mounting Universal size = L - XL Length = 60 cm





Nordic**LINE**

SNOW CHAINS FOR
**TRUCKS AND
BUSES**





CODE	AC	SC	ZZ	NK	NKP
MODEL	ARKTIK CAM	SKANDIC CAM	ZIC ZAC	NORDKAPP	NORDKAPP PLUS
RECOMMENDED FOR					
REINFORCED LINKS		✓	✓	✓	✓
SUITABLE FOR USE ON FRONT WHEELS	✓	✓	✓	✓	✓
POSSIBILITY OF USE ON BOTH SIDES					
USE ON DUAL WHEELS				✓	✓
EASE OF FITTING	**** ***** 9	**** ***** 9	**** ***** 9	**** **** 8	**** **** 8
TRACTION	**** **** 8	**** **** 8	*** **** 7	**** ***** 9	***** ***** 10
DRIVING COMFORT	**** ***** 9	**** **** 8	*** **** 7	**** **** 8	**** **** 8
SIDE GRIP	**** ***** 9	**** ***** 9	**** **** 8	**** **** 8	**** **** 8
WEAR RESISTANCE	**** **** 8	**** ***** 9	**** ***** 9	**** ***** 9	**** ***** 9

ARKTIK CAM

AC



SKANDIC CAM

SC



Truck chain. Strong and reliable.

- Link thickness of 5.5 mm.
- Running surface in rhomboid shape made of special alloy steel, with "D" profile links for safe grip on snow and ice.
- High quality heat treatment – carburising.
- Operating instructions enable fast assembly.

In a bag made of durable fabric.
Packaging: 1 pair per bag.

	D [mm]	5,5
	H [mm]	20



Truck chain. Strong and reliable.

- Link thickness of 5.5 mm.
- Running surface in rhomboid shape made of special alloy steel, with "D" profile links for safe grip on snow and ice.
- With additional welded plates.
- High quality heat treatment – carburising.
- Operating instructions enable fast assembly.

In a bag made of durable fabric.
Packaging: 1 pair per bag.

	D [mm]	5,5
	H [mm]	20



ZIC ZAC

ZZ



Chain for difficult driving conditions. Light and handy chain for fairly powerful vehicles and short distances.

- Useful for trailer wheels as well.
- Link thickness of 7 mm or 8 mm.
- Diagonal construction.
- Running surface in transverse shape, with twisted links and welded elements which prevent sliding.
- High quality heat treatment – carburising.
- Operating instructions enable fast assembly.

In a bag made of durable fabric.

Packaging: 1 pair per bag or ½ pair per bag depending on the size.

		7	8
	φ [mm]	7	8
	$\varphi 1$ [mm]	8	9
	H [mm]	27	31



NORDKAPP

NK



Chain for difficult driving conditions. Light and handy chain for fairly powerful vehicles and short distances.

- Useful for trailer wheels as well.
- Link thickness of 7 or 8 mm.
- Running surface in transverse shape, with twisted links and welded elements which prevent sliding.
- High quality heat treatment – carburising.
- Operating instructions enable fast assembly.

In a bag made of durable fabric.

Packaging: 1 pair per bag or ½ pair per bag depending on the size.

		7	8
	φ [mm]	7	8
	$\varphi 1$ [mm]	8	9
	H [mm]	27	31





NORDKAPP PLUS

NKP



Chain for difficult driving conditions. Light and handy chain for fairly powerful vehicles and short distances.

- Useful for trailer wheels as well.
- Link thickness of 8 mm.
- Denser construction.
- Running surface in transverse shape, with twisted links and welded elements which prevent sliding.
- High quality heat treatment – carburising.
- Operating instructions enable fast assembly.

In a bag made of durable fabric.

Packaging: 1 pair per bag or ½ pair per bag depending on the size

		8
	φ [mm]	8
	φ1 [mm]	9
	H [mm]	31



SNOW CHAINS FOR **ATV, FORKLIFTS**





CODE	PI	ATV	STN	STX	STL
MODEL	PROFI	ATV	STN	STX	STL
RECOMMENDED FOR					
REINFORCED LINKS			✓		
POSSIBILITY OF USE ON BOTH SIDES	✓	✓	✓	✓	✓
RUNNING SURFACE COVERAGE	***** ***** 10	**** ***** 9	***** ***** 10	**** ***** 9	**** ***** 8
TRACTION CAPACITY	***** ***** 10	**** ***** 9	**** ***** 9	**** ***** 9	**** ***** 8
WAER RESISTANCE	***** ***** 10	**** ***** 9	**** ***** 9	**** ***** 9	**** ***** 8

PROFI

PI



Suitable for light mobile machinery, as forklifts and smaller loaders. Designed for difficult conditions and ensuring optimum grip on snow and ice.

- Approved in accordance with the standard ON V5119.
- Chains are net woven and made of special alloy steel for a safer grip on snow and ice.
- High quality heat treatment – carburising.
- Chain links made of "D" profile wire with a thickness of 4,5 mm or 5,5 mm.
- Chains can be used on both sides which significantly improves durability.
- Operating instructions enable fast assembly.

Supplied in a durable fabric bag.
Packaging: 1 pair per bag.

	D [mm]	4,5	5,5
	H [mm]	16	20



ATV

ATV



Made specifically for the use with ATV, UTV and QUAD vehicles. Running surface in a compact rhomboid shape, intended for difficult driving conditions.

- Link thickness of 4.5 mm or 5.5 mm, with a "D" profile link, which ensures a safe grip on snow and ice.
- Special alloy steel.
- High quality heat treatment – carburising.
- The chain is fully galvanized.
- Equipped with a tensioning chain and tensioning hook.
- Operating instructions enable fast assembly.

Supplied in a durable fabric bag.
Packaging: 1 pair per bag.

	D [mm]	4,5	5,5
	H [mm]	16	20



STN

STN



For forklifts and smaller tractors, intended for moderate to demanding use. Running surface in twin asymmetric rhomboid shape with reinforced chain links.

- Link thickness of 4.5 mm or 5.5 mm, with a "D" profile link, which ensures a safe grip on snow and ice.
- Special alloy steel.
- High quality heat treatment – carburising.
- The chain is fully galvanized.
- Equipped with a tensioning chain and tensioning hook.
- Operating instructions enable fast assembly.

Supplied in a durable fabric bag.
Packaging: 1 pair per bag.

	D [mm]	4,5	5,5
	H [mm]	16	20



STX

STX



For garden machinery and manual snow blowers. For light to moderate use in winter conditions. Running surface in rhomboid shape.

- Link thickness of 3.5 mm, 4.5 mm or 5.5 mm, with a "D" profile link, which ensures a safe grip on snow and ice.
- Special alloy steel.
- High quality heat treatment – carburising.
- The chain is fully galvanized.
- Equipped with a tensioning chain and tensioning hook.
- Operating instructions enable fast assembly.

Supplied in a durable fabric bag.
Packaging: 1 pair per bag.

	D [mm]	3,5	4,5	5,5
	H [mm]	12	16	20



STL

STL



Economical solution for garden machinery and manual snow blowers. Running surface in a transverse shape.

- Link thickness of 3,5 mm and 4,5 mm, with a "D" profile link, which ensures a safe grip on snow and ice.
- Special alloy steel.
- High quality heat treatment – carburising.
- The chain is fully galvanized.
- Equipped with a tensioning chain and tensioning hook.
- Operating instructions enable fast assembly.

Supplied in a durable fabric bag.

Packaging: 1 pair per bag.

	D [mm]	3,5	4,5
	H [mm]	12	16

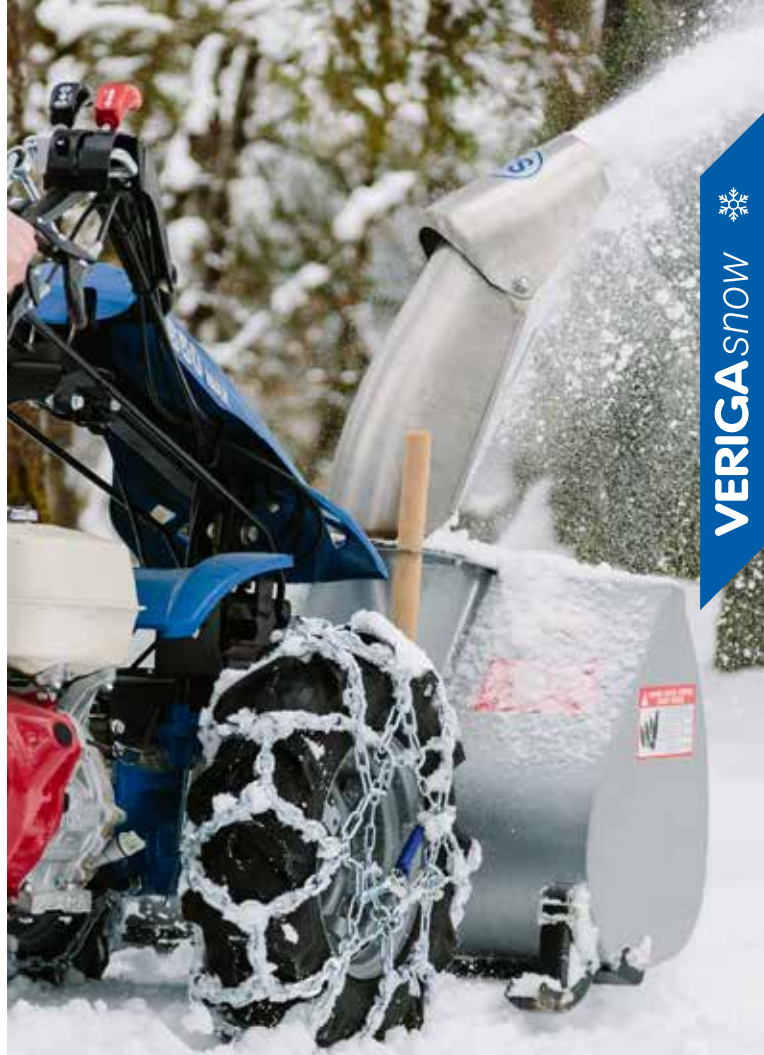

VERIGA snow





Premium**LINE**

SNOW CHAINS FOR **TRACTORS AND HEAVY MACHINERY**





CODE	MG	HG	SEP	SE	SSP	SS	GP
MODEL	MAXI GRIP	HEAVY GRIP	STAR EXTREME PLUS	STAR EXTREME	STAR SUPER PLUS	STAR SUPER	GRENLAND PROFI
RECOMMENDED FOR							
REINFORCED LINKS	✓		✓	✓	✓	✓	
ADDITIONAL WELDED ELEMENTS TO PREVENT WEAR	✓		✓	✓			
POSSIBILITY OF USE ON BOTH SIDES		✓			✓	✓	
RUNNING SURFACE COVERAGE	***** ***** 10	***** ***** 10	**** ***** 9	**** ***** 9	**** ***** 9	**** ***** 9	**** **** 8
TRACTION	***** ***** 10	**** **** 8	**** ***** 9	**** ***** 9	**** ***** 8	**** ***** 8	***** ***** 10
WAER RESISTANCE	***** ***** 10	**** **** 8	**** ***** 9	**** ***** 9	**** ***** 8	**** ***** 8	***** ***** 10

MAXI GRIP

MG



Dense rhomboid-shaped chain, ideal for use in extreme winter conditions and also for use on construction sites. With reinforced links and welded plates for heavy and continuous use in extreme conditions.

- Link thickness of 7 mm, 8 mm, 9.5 mm, or 12 mm with a "D" profile link for a secure grip on snow and ice.
- High quality heat treatment – carburising. Fully galvanized.
- Construction that permits the highest level of protection of the tyre.
- Inner side chain with adjustable shackles for an optimal fit on the tyre.
- Equipped with a tensioning chain and tensioning hook.
- The running and side surfaces are connected by welded rings.

Supplied in a wooden crate.
Packing: 1 pair in a wooden crate.

	D [mm]	7	8	9,5	12
	H [mm]	34	38	44	58



HEAVY GRIP

HG



Dense rhomboid-shaped chain, ideal for professional use in extreme winter conditions and in forestry. The chain is primarily designed for heavy cranes that need a good grip, rather than a high level of protection.

- Link thickness of 7 mm, 8 mm or 9.5 mm with a "D" profile link for a secure grip on snow and ice
- High quality heat treatment – carburising. Fully galvanized.
- Inner side chain with adjustable shackles for an optimal fit on the tyre.
- Equipped with a tensioning chain and tensioning hook.
- The running and side surfaces are connected by welded rings.

Supplied in a wooden crate.
Packing: 1 pair in a wooden crate.

	D [mm]	7	8	9,5
	H [mm]	27	30	35



STAR EXTREME PLUS

SEP



Twin rhomboid-shaped chain, designed for use in extreme winter conditions. Only suitable for vehicles with wider tyres. Reinforced links and welded plates for demanding and continuous use on snow and ice. Ideal for snow ploughing.

- Link thickness of 7 mm, 8 mm, 9.5 mm or 12 mm, with a "D" profile link for a safe and efficient grip on snow and ice.
- High quality heat treatment – carburising. Fully galvanised.
- Inner side chain with adjustment shackles for an optimal fit on the tyre.
- Equipped with a tensioning chain and tensioning hook.
- The running and side surfaces are connected by welded rings.

Packing: 1 pair in a wooden crate.

	D [mm]	7	8	9,5	12
	H [mm]	34	38	44	58



STAR EXTREME

SE



Dense rhomboid-shaped chain, ideal for use in extreme winter conditions. With reinforced links and additional welded plates, for demanding and constant use on snow and ice. Ideal for snow ploughing.

- Approved in accordance with the standard ON V5119.
- Link thicknesses of 7 mm, 8 mm, 9.5 mm, or 12 mm, with a "D" profile link for a safe grip on snow and ice.
- High quality heat treatment – carburising. Fully galvanised.
- Inner side chain with adjustment shackles for an optimal fit on the tyre.
- Equipped with a tensioning chain and tensioning hook.
- The running and side surfaces are connected by welded rings.

Packing: 1 pair in a wooden crate or durable fabric, depending on the size.

	D [mm]	7	8	9,5	12
	H [mm]	34	38	44	58



STAR SUPER PLUS

SSP



Twin rhomboid-shaped chain, designed for professional use in winter conditions. Only suitable for vehicles with wider tyres. Reinforced links for continuous use on snow and ice. Ideal for snow ploughing.

- Link thickness of 7 mm, 8 mm, 9.5 mm, or 12 mm, with a "D" profile link for a safe and efficient grip on snow and ice.
- High quality heat treatment – carburising. Fully galvanized.
- Inner side chain with adjustment shackles for an optimal fit on the tyre.
- Equipped with a tensioning chain and tensioning hook.
- The running and side surfaces are connected by welded rings.
- Use on both sides for longer life.

Packing: 1 pair in a wooden crate.

	D [mm]	7	8	9,5	12
	H [mm]	27	30	35	46



STAR SUPER

SS



Dense rhomboid-shaped chain, ideal for professional use in winter conditions. With reinforced links, for constant use on snow and ice. Ideal for snow ploughing.

- Approved in accordance with the standard ON V5119.
- Link thickness of 7 mm, 8 mm, 9.5 mm, or 12 mm, with a "D" profile link for a safe grip on snow and ice.
- High quality heat treatment – carburising. Fully galvanized.
- Use on both sides for longer life.
- Inner side chain with adjustable shackles for an optimal fit on the tyre.
- Equipped with a tensioning chain and tensioning hook.
- The running and side surfaces are connected by welded rings.

Packing: 1 pair in a wooden crate or durable fabric, depending on the size.

	D [mm]	7	8	9,5	12
	H [mm]	27	30	35	46



GRENLAND PROFI

GP



Dense rhomboid-shaped chain, designed for use in extreme winter conditions. With flat grippy elements for better traction. For demanding and continuous use on snow and ice.

- Link thickness of 8 mm. Plates providing a secure grip on snow and ice.
- High quality heat treatment - cementation.
- Inner side chain with adjustment shackles for an optimal fit on the tyre.
- Equipped with a tensioning chain and tensioning hook.
- The running and side surfaces are connected by welded rings.
- Unique construction ensures additional tyre protection.

Packing: in a wooden crate.

Packing: 1 pair in a wooden crate.

	D [mm]	8
	H [mm]	40

*Rings: 11 mm



VERIGA SNOW

SNOW CHAINS FOR **TRACTORS AND HEAVY MACHINERY**





CODE	GR	TM	TR	GS
MODEL	GRENLAND	TEMPO	TRACTOR	GRIP STUD
RECOMMENDED FOR				
REINFORCED LINKS			✓	
ADDITIONAL WELDED ELEMENTS TO PREVENT WEAR				✓
POSSIBILITY OF USE ON BOTH SIDES		✓	✓	
RUNNING SURFACE COVERAGE	*** *** 6	**** **** 8	**** *** 7	**** **** 8
TRACTION	**** ***** 9	**** *** 7	**** *** 7	**** **** 8
WAER RESISTANCE	***** ***** 10	**** *** 7	**** *** 7	**** **** 8

GRENLAND

GR



Rhomboid-shaped chains, designed for use in harsh winter conditions. With flat grippy elements for better traction. For demanding use on snow and ice.

- Link thickness of 8 mm. Plates providing a secure grip on snow and ice.
- High quality heat treatment - cementation.
- Inner side chain with adjustment shackles for an optimal fit on the tyre.
- Equipped with a tensioning chain and tensioning hook.
- The running and side surfaces are connected by welded rings.

Packing: 1 pair in a wooden crate.

	D [mm]	8
	H [mm]	40

* rings: 11 mm



TEMPO

TM



Rhomboid-shaped chain, ideal for standard agricultural use.

- Link thickness of 7 mm, 8 mm, or 9.5 mm, with a "D" profile link for a safe grip on snow and ice.
- High quality heat treatment – carburising. Fully galvanized.
- Use on both sides for longer life.
- Inner side chain with adjustable shackles for an optimal fit on the tyre.
- Equipped with a tensioning chain and tensioning hook.
- The running and side surfaces are connected by welded rings.

Packing: 1 pair in a wooden crate or durable fabric, depending on the size.

	D [mm]	7	8	9,5
	H [mm]	27	30	35



TRACTOR

TR



Ladder-shaped chain, for light agricultural use. Simple and functional. With reinforced rings on longitudinal links.

- Link thickness of 6 mm, 7 mm, 8 mm, or 9,5 mm, with a "D" profile link for a safe grip on snow and ice.
- High quality heat treatment – carburising. Fully galvanized.
- Use on both sides for longer life.
- Equipped with a tensioning chain and tensioning hook.

Packing: 1 pair in a wooden crate or durable fabric, depending on the size.

	D [mm]	6	7	8	9,5
	H [mm]	23	26	30	35



GRIP STUD

GS



Tractor chain for forestry, intended for less demanding surfaces. The chain is distinguished by good driving properties and grip.

- Due to its construction, the chain is easy to use.
- Made of special alloy steel and fully heat treated, which extends its life span additionally.
- Available in 8,5 mm, 10 mm and 12 mm versions.

Packing: 1 pair in a wooden crate or durable fabric, depending on the size.

		8,5	10	12
	φ [mm]	8	9,5	11
	φ1 [mm]	9	10	12,5
	H [mm]	30	34	41





LASHING CHAIN SYSTEMS G100

3.5 M TWO-PART KIT FOR FASTENING EN 12195-3

Two-part kit

Code	Grade	Chain (mm)	LC (kN)	STF (daN)	Ratchet	kg
37148	100	8	50	3000	37150	11,2
37149	100	10	80	3000	37151	16

Ratchet

Code	d (mm)	c (mm)	e/f (mm)	g (mm)	a (mm)	b (mm)
37150	250	11	620/770	10	280	56
37151	260	15	710/880	12	280	64

Additional chain

Code	Grade	Chain (mm)	Dimension (mm)	kg/m
31196	DIN 818-2	8	8x24	1,6
37716	DIN 818-2	10	10x30	2,5

Standard length of the kit is 3.5 m. According to the customer request, we can produce optional kit length.

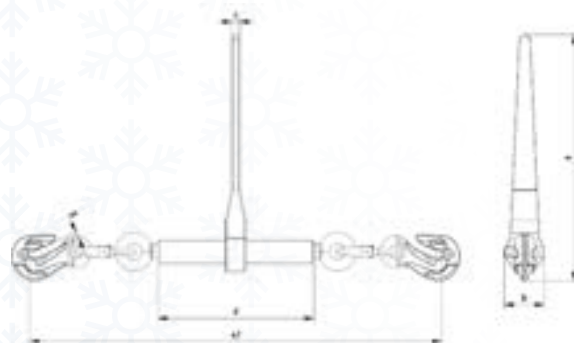

KIT FOR FASTENING THE LOAD EN 12195-3



Kitchain

Code	Grade	Chain (mm)	LC (kN)	STF (daN)	kg
37146	100	8	50	3000	9,7
37147	100	10	80	3000	14,7

Additional chain

Code	Grade	Chain (mm)	Dimension (mm)	kg/m
31196	DIN 818-8	8	8x24	1,6
37716	DIN 818-8	10	10x30	2,5

Standard length of the kit is 3,5 m. According to the customer request, we can produce optional kit length.

RATCHET WITH HOOKS FOR FASTENING THE LOAD EN 12195-3

Code	Grade	Chain (mm)	LC (kN)	MBL (kN)	kg
39443	100	8	50	100	3,7
39444	100	10	80	160	6



Code	d (mm)	c (mm)	e/f (mm)	g (mm)	a (mm)	b (mm)
39443	250	11	620/770	10	280	56
39444	260	15	710/880	12	280	64

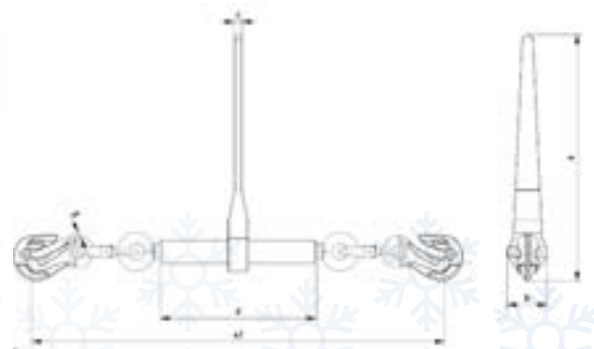

RATCHET FOR FASTENING THE LOAD EN 12195-3

Code	Grade	Chain (mm)	LC (kN)	MBL (kN)	kg	d (mm)	c (mm)	e/f (mm)	g (mm)	a (mm)	b (mm)
37152	100	8	50	100	2,4	250	11	360/530	20	280	56
37153	100	10	80	160	3,8	260	15	380/560	20	280	64

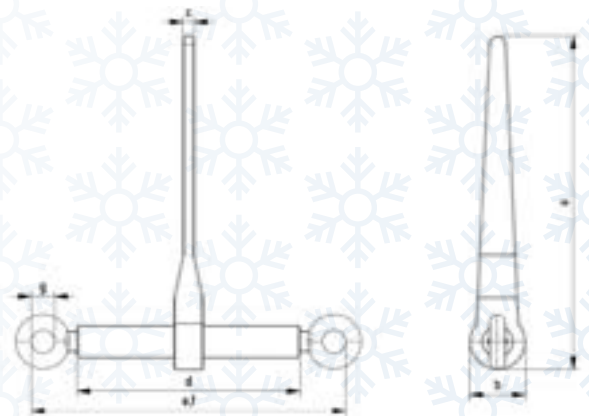

LOAD HOOK WITH A BLOCK EN 1677

Code	Grade	Chain (mm)	WLL (t)	MBL (t)	kg	e (mm)	h (mm)	a (mm)	d (mm)	g1 (mm)	b (mm)
37156	100	8	2,5	10	0,7	92,5	31	20	10	33	90,5
37157	100	10	4	16	1,2	109,5	37	26	13	40	108,5

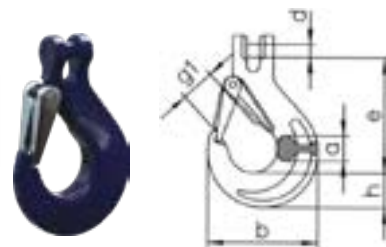

SHORTENING HOOK EN 1677

Code	Grade	Chain (mm)	WLL (t)	MBL (t)	kg	e (mm)	b (mm)	d1 (mm)	d2 (mm)	g (mm)
37154	100	8	2,5	10	0,5	70	58	20	12	10
37155	100	10	4	16	1,0	88	70	21	14	12



CHAIN CONNECTOR EN 1677

Code	Grade	Chain (mm)	WLL (t)	MBL (t)	kg	e (mm)	c (mm)	s (mm)	d (mm)	b (mm)	g (mm)
34734	100	8	2,5	10	0,2	63	10	16	9,5	53	19
34781	100	10	4,0	16,0	0,35	70,5	13,5	19	11,5	65	24

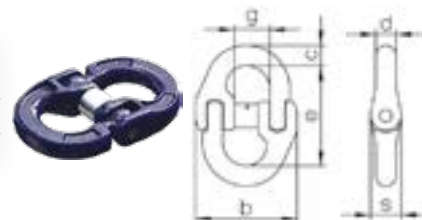

MASTER LINK EN 1677

Code	Grade	Chain (mm)	WLL (t)	MBL (t)	kg	d (mm)	w (mm)	s (mm)	t (mm)
34733	100	8	3,5	14,0	0,5	16	60	10	110
34780	100	10	5,0	20,0	0,85	18	75	10	135





LASHING CHAIN SYSTEMS G80

3.5 M TWO-PART KIT FOR FASTENING EN 12195-3

Two-part kit

Code	Grade	Chain (mm)	LC (kN)	STF (daN)	Ratchet	kg
34077	80	8	40	1900	33864	11
34079	80	10	63	1900	33865	15,7
34080	80	13	100	3000	33866	24

Ratchet

Code	d (mm)	c (mm)	e/f (mm)	g (mm)	a (mm)	b (mm)
33864	250	11	620/770	10	280	56
33865	260	15	710/880	12	280	64
33866	260	16	820/990	16	355	64

Additional chain

Code	Grade	Chain (mm)	Dimension (mm)	kg/m
34268	DIN 818-2	8	8x24	1,4
34269	DIN 818-2	10	10x30	2,2
34270	DIN 818-2	13	13x39	3,8

Standard length of the kit is 3.5 m. According to the customer request, we can produce optional kit length.

LC: Lashing Capacity
STF: standard tension force
MBL: Minimum breaking load
WLL: max. Working Load Limit



KIT FOR FASTENING THE LOAD EN 12195-3

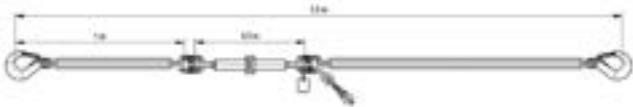

Kit

Code	Grade	Chain (mm)	LC (kN)	STF (daN)	kg
33917	80	8	40	1900	9,5
33918	80	10	63	1900	14,4
33919	80	13	100	3000	21,5

Additional chain

Code	Grade	Chain (mm)	Dimension (mm)	kg/m
34268	DIN 818-2	8	8x24	1,4
34269	DIN 818-2	10	10x30	2,2
34270	DIN 818-2	13	13x39	3,8

Standard length of the kit is 3.5 m. According to the customer request, we can produce optional kit length.

RATCHET WITH HOOKS FOR FASTENING THE LOAD EN 12195-3

Code	Grade	Chain (mm)	LC (kN)	MBL (kN)	kg
39440	80	8	40	80,4	5
39441	80	10	63	126	5,5
39442	80	13	100	212	7,7

Code	d (mm)	c (mm)	e/f (mm)	g (mm)	a (mm)	b (mm)
39440	250	11	620/770	10	280	56
39441	260	15	710/880	12	280	64
39442	260	16	820/990	16	355	64

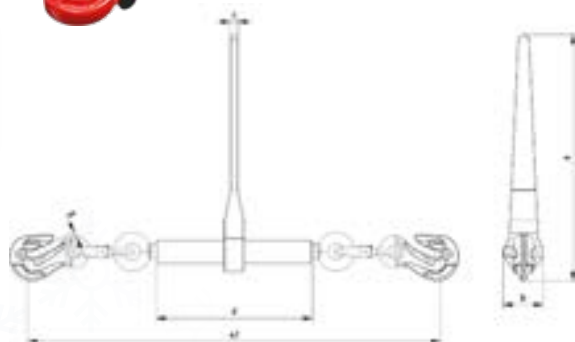

RATCHET FOR FASTENING THE LOAD EN 12195-3

Code	Grade	Chain (mm)	LC (kN)	MBL (kN)	kg	d (mm)	c (mm)	e/f (mm)	g (mm)	a (mm)	b (mm)
33861	80	8	40	80,4	3,5	250	11	360/530	20	280	56
33862	80	10	63	126	3,5	260	15	380/560	20	280	64
33863	80	13	100	212	4,0	260	16	400/580	25	355	64

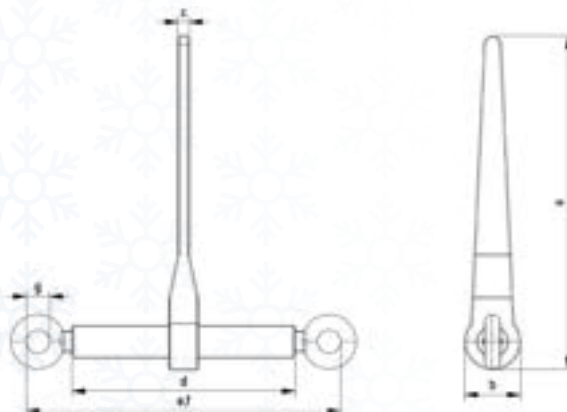

LOAD HOOK WITH A BLOCK EN 1677

Code	Grade	Chain (mm)	WLL (t)	MBL (t)	kg	e (mm)	h (mm)	a (mm)	d (mm)	g1 (mm)	b (mm)
33876	80	8	2	8	0,7	92,5	31	20	10	33	90,5
33877	80	10	3,15	12,6	1,3	109,5	37	26	13	40	108,5
33878	80	13	5,3	21,3	2,4	134	44	33	16,5	49	133

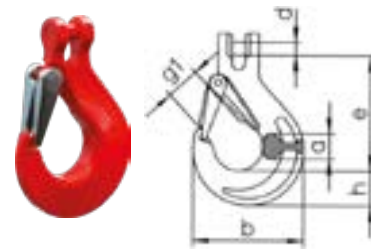

SHORTENING HOOK EN 1677

Code	Grade	Chain (mm)	WLL (t)	MBL (t)	kg	e (mm)	b (mm)	d1 (mm)	d2 (mm)	g (mm)
33873	80	8	2	8	0,4	70	58	20	12	10
33874	80	10	3,15	12,6	0,8	88	70	21	14	12
33875	80	13	5,3	21,3	1,6	106	93	27	19	16

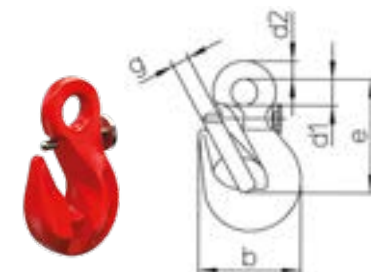

CHAIN CONNECTOR EN 1677

Code	Grade	Chain (mm)	WLL (t)	MBL (t)	kg	e (mm)	c (mm)	s (mm)	d (mm)	b (mm)	g (mm)
33871	80	8	2	8	0,2	63	10	16	9,5	53	19
33870	80	10	3,15	12,6	0,4	70,5	13,5	19	11,5	65	24
33872	80	13	5,3	21,3	0,7	90	16	26	15	82	29

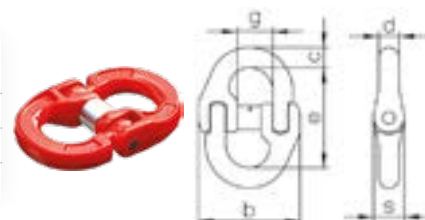











MASTER LINK EN 1677

Code	Grade	Chain (mm)	WLL (t)	MBL (t)	kg	d (mm)	w (mm)	s (mm)	t (mm)
33879	80	8	2,12	8,5	0,6	16	60	10	110
33880	80	10	3,15	12,6	0,9	18	75	10	135
33881	80	13	5,3	21,3	1,5	20	90	10	160





SPARE PARTS

	Code	Cross chain hook	Pcs.	For Chain		Code	Chain fastener	Pcs.	For Chain
	29123	3,5	10	-> 3,5 mm		29158	No. 2	2	8-9,5 mm
	30065	5	10	4,5-5,5 mm		29161	No. 4	2	4,5-5,5 mm
	29118	6	10	5,5 mm		29162	No. 5	2	3,5-4,5 mm
	29120	8	10	6-8,5 mm		29163	No. 7	2	6-8 mm
	33825	9,5	5	9,5-10		33828	GS 8,5	L+D	GS 8,5
33826	11	5	12	33829	GS 12	L+D	GS 10, GS 12		
	Code	Side hook "K"	Pcs.	For Chain		Code	Emergency link	Pcs.	For Chain
	29156	K 1	2	3,5 mm		29221	D 6	10	6 mm
	34272	K 3	2	4,5 mm		29222	D 8	10	7-8 mm
	29124	K 4	2	7-9,5 mm		29223	D 10	5	8-10 mm
41003	K6	2	5,5						
	Code	Hook "H"	Pcs.	For Chain		Code	Quick link "T"	Pcs.	For Chain
	30840	H 10	2	4,5 mm		42173	T 07	2	4,5-5,5 mm
	30841	H 15	2	5,5 mm		30044	T 06	2	5,5-7 mm
	30842	H 30	2	7-8 mm		30045	T 08	2	7-8 mm
	29169	H 40	2	7-8 mm		30046	T 10	2	9-11 mm
	29170	H 60	2	9,5 mm		30047	T 13	2	14 mm
29171	H 80	2	12 mm	30048	T 16	2	16 mm		
	Code	Shakle G80	Pcs.	For Chain		Code	Shakle	Pcs.	For Chain
	33024	5	1	4,5-5,5 mm		29164	5	6	4,5-5,5 mm
	33205	8	1	7-11 mm		29166	8	6	7-9 mm
33026	11	1	14-16 mm	29167	11	6	11-16 mm		
	Code	Spring hook with carabin	Pcs.	For Chain		Code	Rubber hook	Pcs.	For Chain
	29179	D 2,5	2	4,5-7 mm		28879	D 10	1	3-4,5 mm
30843	D 3	2	7-9,5 mm	27161	D 17	1	4,5 mm		
	Code	Hook "R"	Pcs.	For Chain		Code	Assembly link	Pcs.	For Chain
	29212	R	5	7-9,5 mm		29224	DV 8	6	7-8 mm
	Code	Side chain repair link	Pcs.	For Chain		Code	Spare link	Pcs.	For Chain
	29204	D 3,5	15	3,5 mm		29214	DV 5,5	10	5,5 mm
	29205	D 5	10	4,5-5,5 mm		29216	DV 7	10	7 mm
	29206	D 6	10	6-7 mm		29217	DV 8	5	8 mm
	29207	D 8	10	8 mm		29218	DV 10	5	9,5 mm
29208	D 10	5	9,5 mm						

	Code	Ring open	Pcs.	For Chain
	30067	5x19	10	4,5 mm
	30056	7x24	10	5,5 mm
	30058	10x45	5	9,5-11 mm
	30057	8x35	10	7-8 mm
	29189	9x30	10	7-8 mm
	29202	14x50	3	12-14 mm
	29201	11x40	5	9,5-11 mm
	33034	15x56	3	14 mm
	29203	16x56	3	16 mm
	33037	18x60	3	18 mm
	33830	18x74	3	19 mm

	Code	Lock	Pcs.	For Chain
	30621	PRO COMPACT (9-12)	1	PC9, PC12, SEV

	Code	Lock	Pcs.	For Chain
	29834	PROFESSIONAL	1	PN

	Code	Lock	Pcs.
	40869	STOP&GO SG7,SG9,SG13	1

	Code	Bag	Dimensions	Pcs.
	42178	TM, TR, GS	40x60	1
	42179	TM, TR, GS	50x70	1

	Code	Bag	Dimensions	Pcs.
	42177	STX, STL, ATV	30x70	1
	42180	A, AS	30x50	1
	42181	A, AS	40x60	1
	42182	A, AS	50x70	1
	42183	NK, NKP, NKD, ZZ	30x50	1
	42184	NK, NKP, NKD, ZZ	40x60	1
	42185	NK, NKP, NKD, ZZ	50x70	1

	Code	Bag	Dimensions	Pcs.
	42186	MT, MD, PI, PS, PE, SS, SE	M P	1
	42187	MT, MD, PI, PS, PE, SS, SE	S P	1
	42188	MT, MD, PI, PS, PE, SS, SE	V P	1
	42190	PRF		1

	Code	H Hook + Ring	Pcs.	For Chain
	33898	H15 + D7x24 (5,5 mm)	1	5,5 mm
	33899	H30 + D9x30 (7-8 mm)	1	7-8 mm
	33900	H40 + D9x30 (7-8 mm)	1	7-8 mm
	33901	H60 + D11x40 (9,5 mm)	1	9,5 mm

	Code	Omega repair link	Pcs.	For Chain
	29117	D 11 (11mm)	1	11 mm
	27368	D 14 (14mm)	1	14 mm
	27592	D 16 (16mm)	1	16 mm
	32477	D 18 (18mm)	1	18 mm
	33048	D 20 (20mm)	1	20 mm

	Code	Plastic hook	Pcs.	For Chain
	30813	PRO COMPACT (9-12)	1	PC9, PC12, SEV

	Code	Bag	Pcs.	For Chain
	29941	PRO COMPACT (9-12)	1	PC9, PC12, SEV
	29842	PROFESSIONAL	1	PN

	Code	Mounting clamp	Pcs.
	33376	KLESCE MON	1

	Code	Spring pins releaser	Pcs.
	30576	IZB VZMET ZATIKOV	1

	Code	Extention	Pcs.	For Chain
	33894	POD D5x35	1	5,5 mm
	33896	POD D7x42	1	7 mm

	Code	Gloves for mounting	Pair
	25604	RM-LXL	1
		Universal length = L - XL Lenght = 60 cm	

Questionnaire Tyre Chains Order Form

Used on: *





































Vehicle information:

Weight of loaded vehicle* [kg]:

Motor power* [kW]:

Tyre information:

Tyre manufacturer¹:

Profile / abeling¹:

Tyre dimension¹:

Single

Double

Type:

Radial

Diagonal

Industrial

Superelastic

<p>Tyre measurements¹:</p> <p>D = _____ mm</p> <p>B = _____ mm</p> <p>B1 = _____ mm</p> <p>B2 = _____ mm</p>	<p>Minimal distance:</p> <p>a = _____ mm</p> <p>b = _____ mm</p> <p>c = _____ mm</p> <p>d = _____ mm</p>
--	---

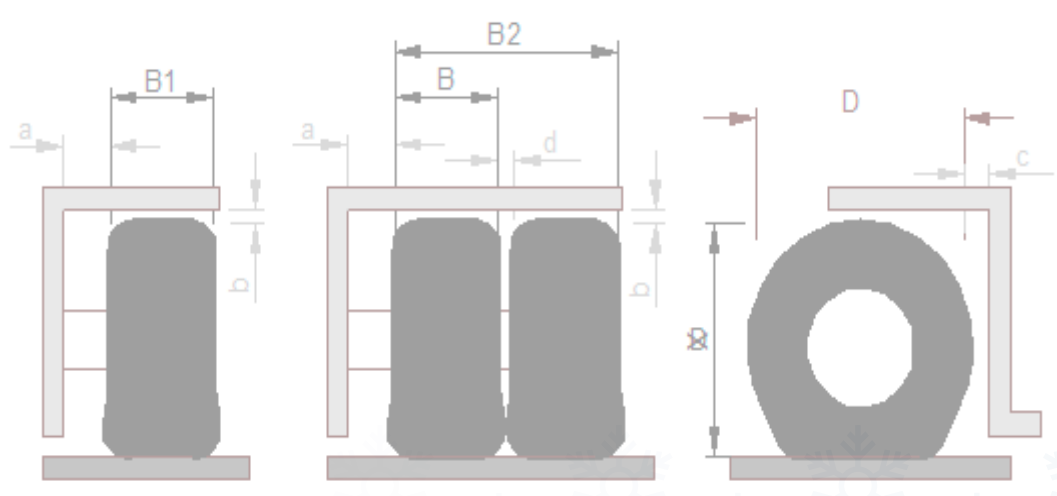

Contact person:

Name: _____

Company: _____

Phone: _____

E-mail: _____

¹ Fill in the form with unambiguous and clear tyre information.
 * Fill-in mandatory

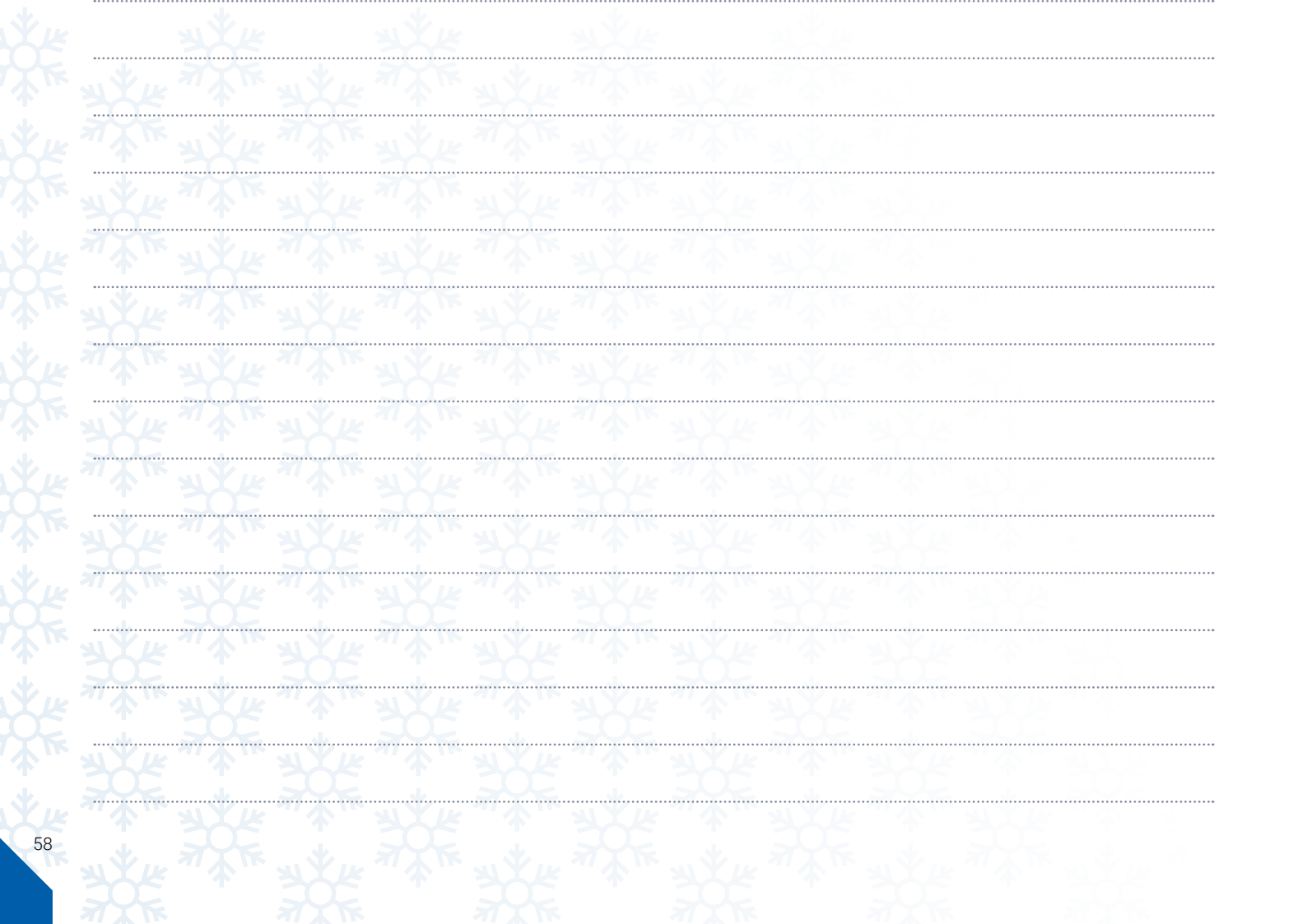



A series of horizontal dotted lines for handwriting practice, spanning the width of the page.

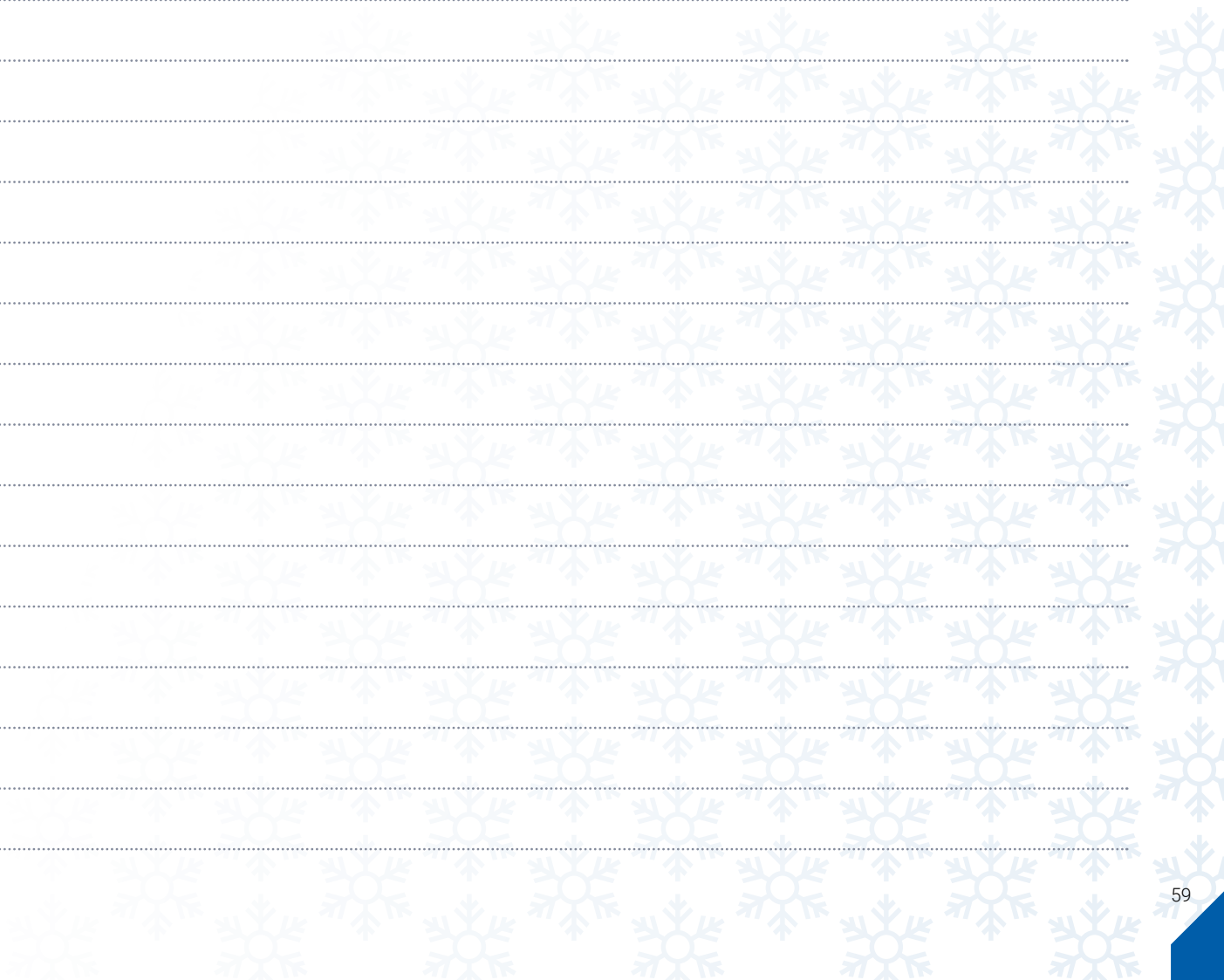



VERIGA K.F., d.o.o.

Alpska cesta 43
 SI - 4248 Lesce
 Slovenia, EU

T.: +386 (0)4 537 09 00
 E.: info@veriga-lesce.com
 W.: www.veriga-lesce.com

Follow us



[verigalesce](https://www.facebook.com/verigalesce)



[veriga_lesce](https://www.instagram.com/veriga_lesce)



2022 / 2023