



FONTAINE
FIFTH WHEEL
FIT FOR THE
LONG HAUL

[FONTAINEFIFTHWHEEL.COM](http://fontainefifthwheel.com)



YOUR FLEET FIT FOR THE LONG HAUL



Fontaine Fifth Wheel are specialists in truck and trailer coupling

We work at the forefront of haulage technology to keep your fleet on the road and off the repair list.

Our specialist experience, knowledge and expertise enables us to offer a broad range of technically tailored options – meeting your exacting needs.

On top of our world-class products, we support our customers just as well as we service their fleets – doing the right thing, in the right way, at the right time to build valued long-term partnerships that go the distance. Combining our fifth wheel expertise and service ethos to ensure your fleet will always be fit for the long haul.

Just like many of our long-term partnerships, we've been around for a while. Our expertise has grown steadily since John Fontaine founded the *Fontaine Truck Equipment Company* back in 1940. Soon after, he invented the very first pressed steel fifth wheel and we've been pushing the boundaries ever since to become a global fifth wheel manufacturer.

Global outlook, tailored approach

As an integral part of the Marmon Group, we operate within the Highway Technology sector – which services the heavy-duty truck industry with a wide range of high quality truck and trailer components, including fifth wheels.

Marmon Holdings Inc is part of Berkshire Hathaway Inc, a global diversified industrial organisation. This means we have the support of a global group, but at the same time, the independence of a niche technology manufacturer.



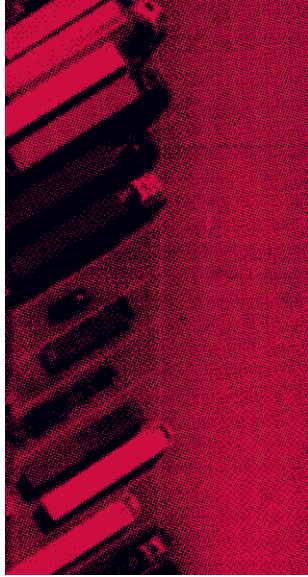

FIT FOR SAFETY

As the inventors of the world-renowned TechLock® system, we work at the forefront of automotive safety technology.

This means you can feel safe in the knowledge that we are continuously improving haulage safety standards.

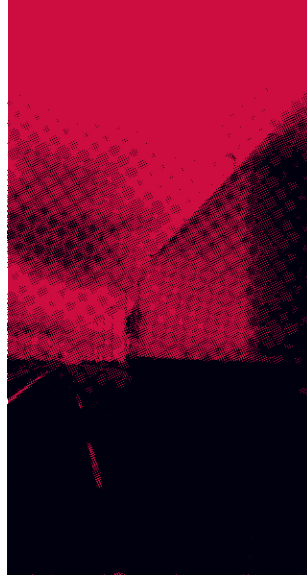

FIT FOR RELIABILITY

Haulage is a tough, uncompromising business and your equipment needs to be fit for purpose.

This is why we design, develop, manufacture and test the most robust and reliable fifth wheels on the market... keeping you on the road and off the repair list.

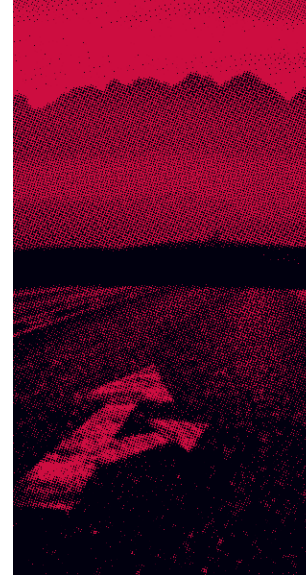

FIT FOR VERSATILITY

We provide on and off-road options for standard, medium or heavy duty use – alongside a host of features that can be tailored to meet your exacting requirements.

So whether you're moving hotdogs or heavy logs, we'll have a set-up that fits the bill.



FIT FOR EFFICIENCY

In the transport and haulage business, time really is money.

Our responsive sales and service teams can be relied upon to quickly and efficiently help you in any way they can – with a friendly smile and a steely determination to get the job done right first time.

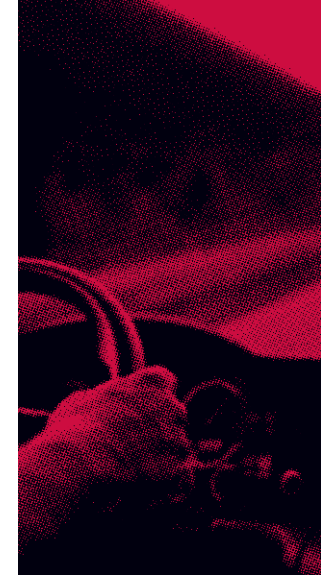

FIT FOR ECONOMY

We believe our whole Fontaine Fifth Wheel 'package' will keep you fit for the long haul by saving time and hassle.

We do this by providing safe, reliable, versatile and efficient fifth wheels coupled with first-class support from our experienced team.

FIT FOR PURPOSE

FIT FOR SAFETY TECHLOCK® SYSTEM



No contact, no couple

Specifically designed to reduce miscoupling, our patented TechLock® system's jaw height sensor will not allow the fifth wheel to close if the kingpin enters at the incorrect height or position.

Jaw protection

Our profiled protective forging safeguards the TechLock® mechanism from damage due to high-coupling errors.

Reducing kingpin wear

360° kingpin surface contact extends the life of the kingpin and fifth wheel mechanism.

Light weight, heavy duty

Our low weight, high strength fifth wheels are designed to provide a long product life cycle.

Confidence as standard

Intelligent design and robust manufacturing standards allows us to offer a comprehensive three year warranty as standard.

150SP² STANDARD DUTY 2" ON-ROAD PRESSED

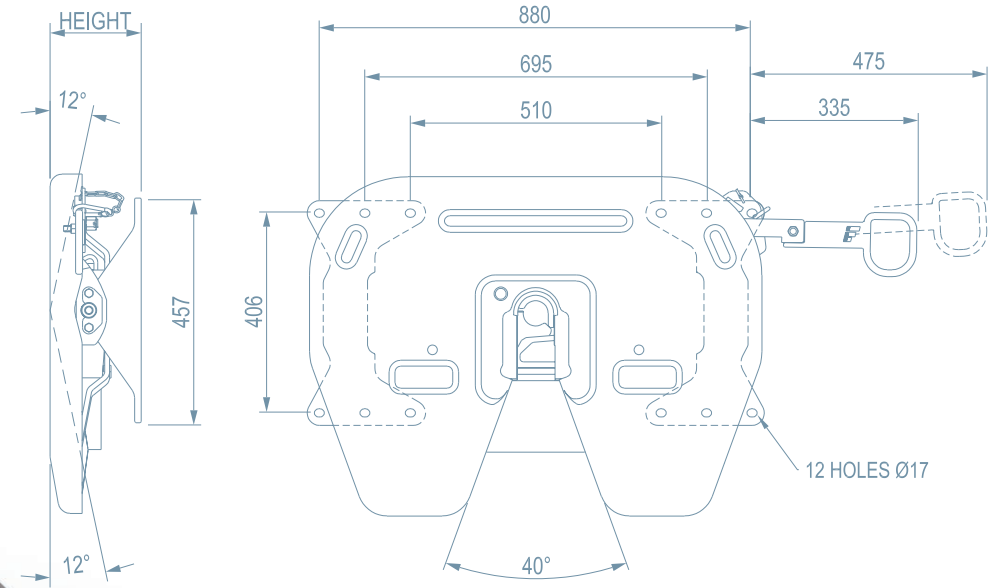

Reducing kingpin wear

The 150SP² does not require a wear ring.



Fit for... Flexible haulage volume carriers using two and three-axle tractors.

E11 55R-01 APPROVAL NO.	HEIGHT MM (DIN 6)	WEIGHT KG	IMPOSED (U) T	D-VALUE KN
E11 55R-01 7166	138mm	115kg	20T	152kN
E11 55R-01 7166	148mm	113kg	20T	152kN
E11 55R-01 7166	161mm	115kg	20T	152kN
E11 55R-01 7166	185mm	117kg	20T	152kN
E11 55R-01 7166	210mm	122kg	20T	152kN
E11 55R-01 7166	230mm	130kg	20T	152kN
E11 55R-01 7166	257mm	133kg	20T	152kN

3000 MEDIUM DUTY 2" ON-ROAD & LIMITED OFF-ROAD

CAST

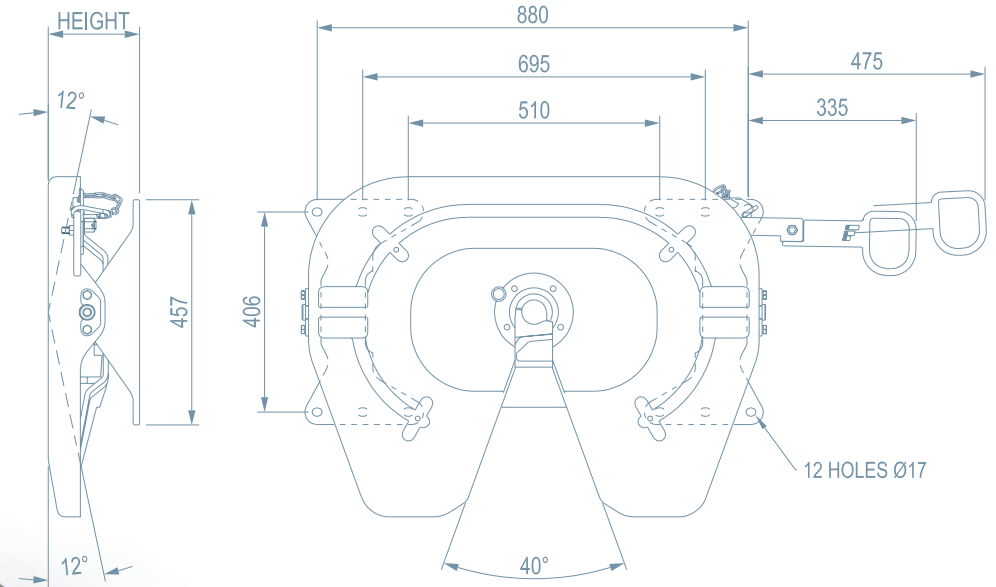

Fit for... Long-distance haulage with silo, tank and volume carriers using both two and three-axle tractors.

<i>E11 55R-01</i> <i>APPROVAL NO.</i>	<i>HEIGHT</i> <i>MM (DIN 6)</i>	<i>WEIGHT</i> <i>KG</i>	<i>IMPOSED (U)</i> <i>T</i>	<i>D-VALUE</i> <i>KN</i>
E11 55R-01 4932	138mm	122kg	20T	150kN
E11 55R-01 4902	148mm	120kg	20T	150kN
E11 55R-01 4903	161mm	122kg	20T	150kN
E11 55R-01 4904	185mm	124kg	20T	150kN
E11 55R-01 4905	210mm	129kg	20T	150kN
E11 55R-01 4906	230mm	137kg	20T	150kN
E11 55R-01 4907	257mm	140kg	20T	150kN

3000LM LOW MAINTENANCE

MEDIUM DUTY 2" ON-ROAD & LIMITED OFF-ROAD

CAST

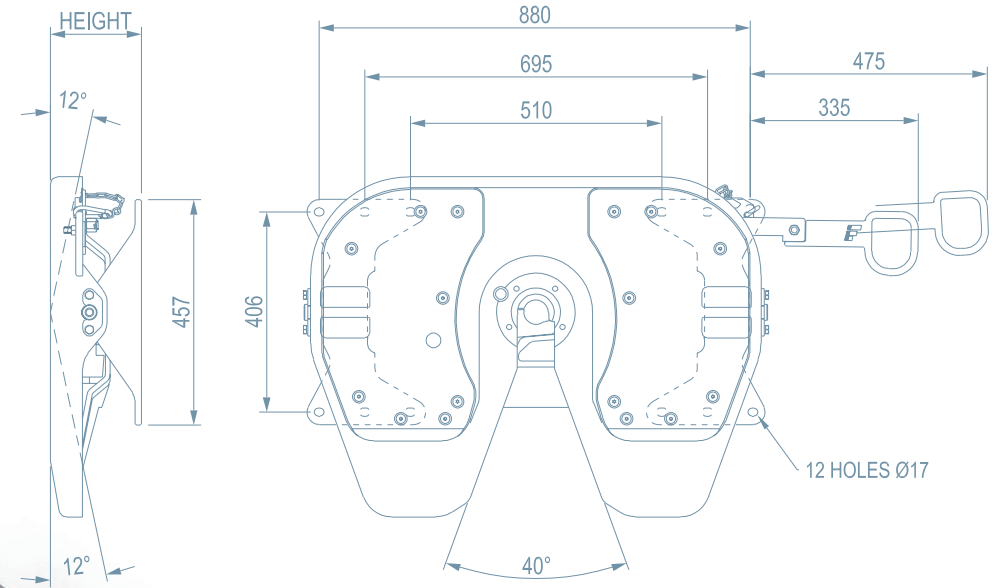

Fit for... Long-distance haulage with silo, tank and volume carriers using both two and three-axle tractors.

<i>E11 55R-01</i> <i>APPROVAL NO.</i>	<i>HEIGHT</i> <i>MM (DIN 6)</i>	<i>WEIGHT</i> <i>KG</i>	<i>IMPOSED (U)</i> <i>T</i>	<i>D-VALUE</i> <i>KN</i>
E11 55R-01 5557	138mm	122kg	20T	152kN
E11 55R-01 5557	148mm	120kg	20T	152kN
E11 55R-01 5557	161mm	122kg	20T	152kN
E11 55R-01 5557	185mm	124kg	20T	152kN
E11 55R-01 5557	210mm	129kg	20T	152kN
E11 55R-01 5557	230mm	137kg	20T	152kN
E11 55R-01 5557	257mm	140kg	20T	152kN

163CI

HEAVY DUTY 2" ON-ROAD & OFF-ROAD

CAST

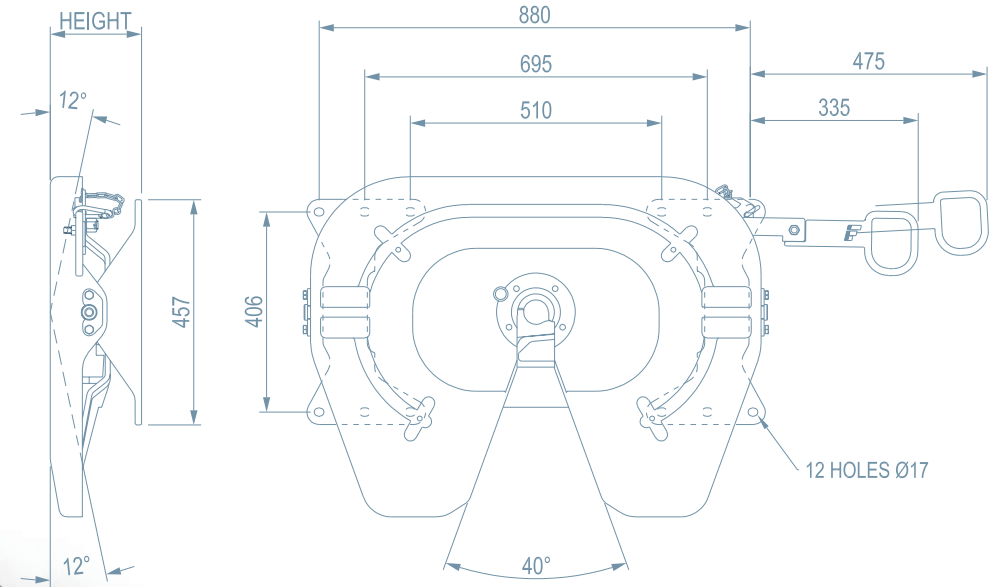

Fit for... HGV traffic and off-road terrain.

E11 55R-01 APPROVAL NO.	HEIGHT MM (DIN 6)	WEIGHT KG	IMPOSED (U) T	D-VALUE KN
E11 55R-01 2883	148mm	140kg	23T	163kN
E11 55R-01 2883	161mm	142kg	23T	163kN
E11 55R-01 2883	185mm	144kg	23T	163kN
E11 55R-01 2883	210mm	149kg	23T	163kN
E11 55R-01 2883	230mm	157kg	23T	163kN
E11 55R-01 2883	257mm	160kg	23T	163kN

SAFETY SENSORS, LUBRICATION & AIR SYSTEMS

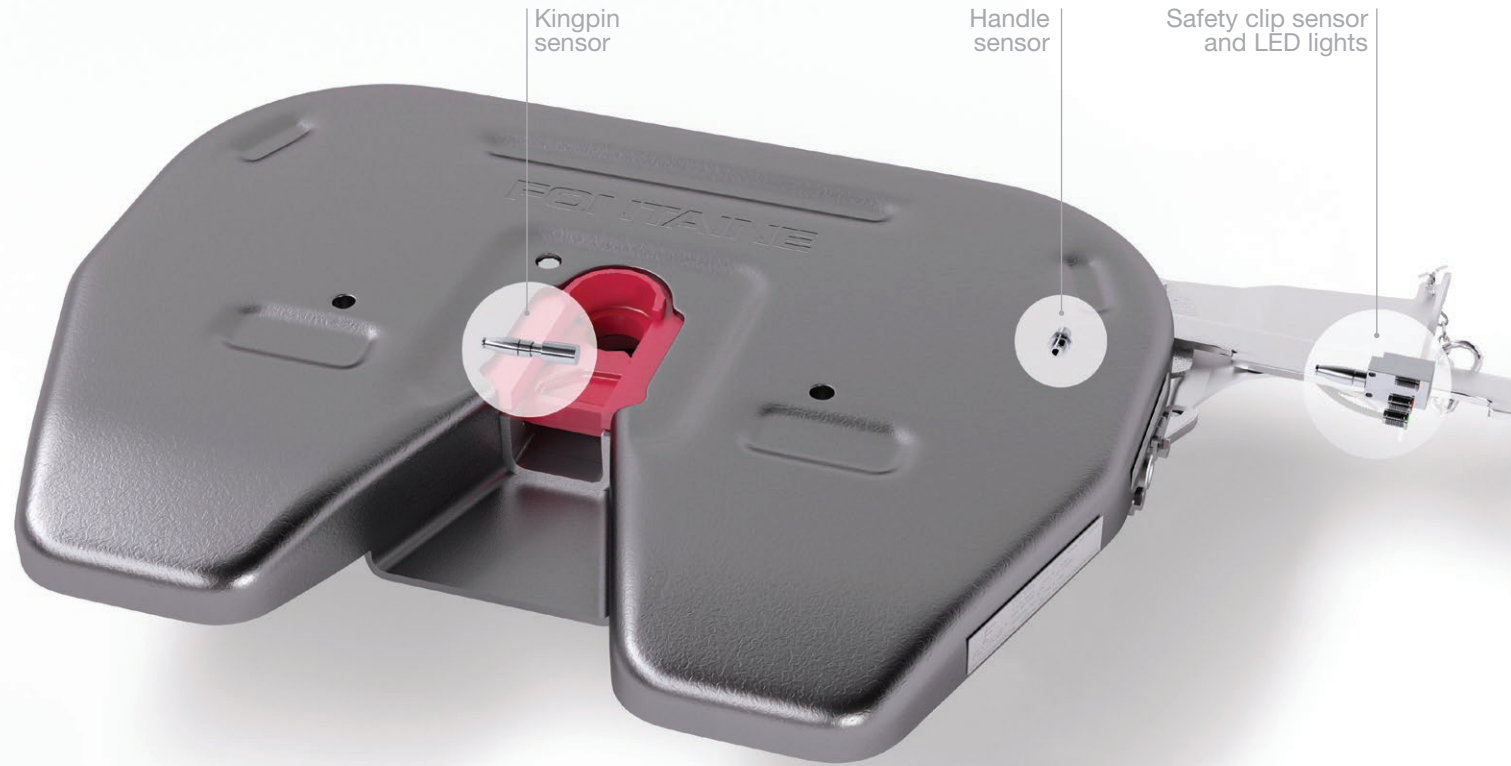

Kingpin sensor

Handle sensor

Safety clip sensor and LED lights

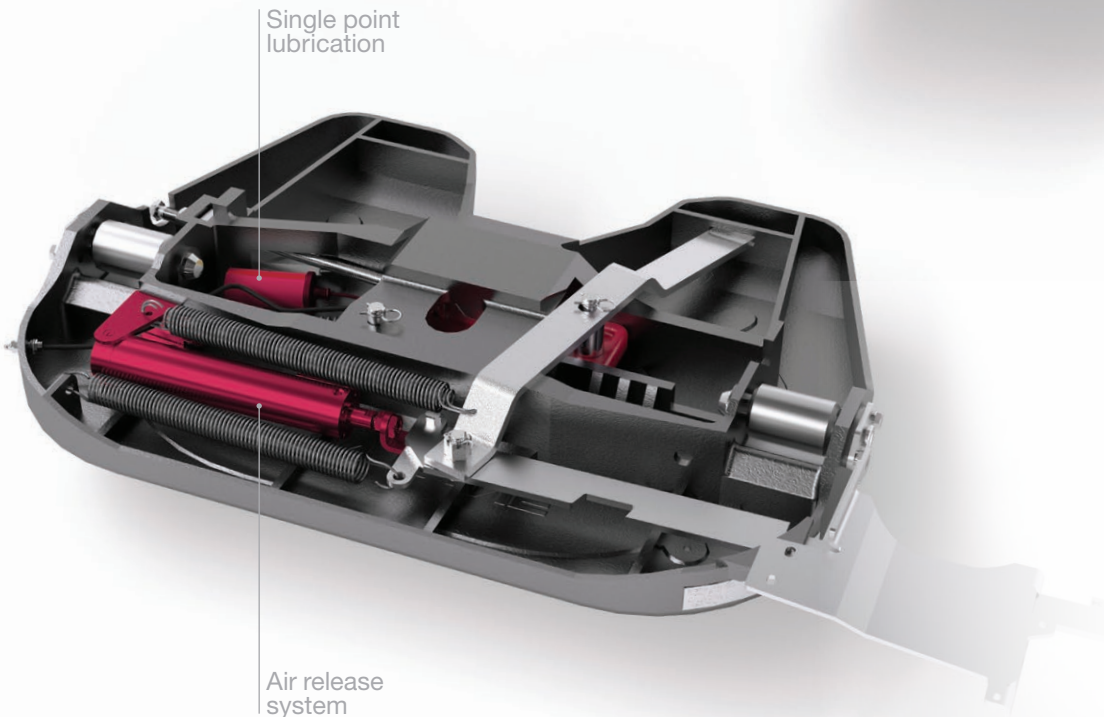

Single point lubrication

Air release system

Fail-safe sensors

Our three-sensor safety system was the first of its kind to alert a driver from inside the cab as well as during the coupling procedure.

Being constantly monitored, the system uses warning lights and a buzzer to alert any miscoupling or tampering.

Green Eye LED light and single sensor

The Green Eye indicates when the fifth wheel is correctly closed and that the driver has carried out his checks.

Single point lubrication

This system delivers grease automatically to the kingpin and can be set in intervals of 1–12 months, providing service peace-of-mind.

Air release systems

Our air operated mechanisms remove the need to manually operate the release handle, reducing the physical demand on the driver.

This feature is available on both fixed and sliding fifth wheel products.

HANDLE OPTIONS



Standard

Our standard safety clip fifth wheel handle is designed for ease of use and built to last.

Interlock

As an alternative to our safety clip system, the interlock removes the need for a clip by integrating the safety mechanism into the handle itself.

Extended

To aid access, our easy-to-use extended handle helps drivers reach and operate the fifth wheel handle and safety clip more comfortably.

MOUNTING OPTIONS

Our range of mounting options ensures all Fontaine fifth wheels suit a broad range of applications on all European chassis. See our specification chart at the end of this brochure for full technical details.

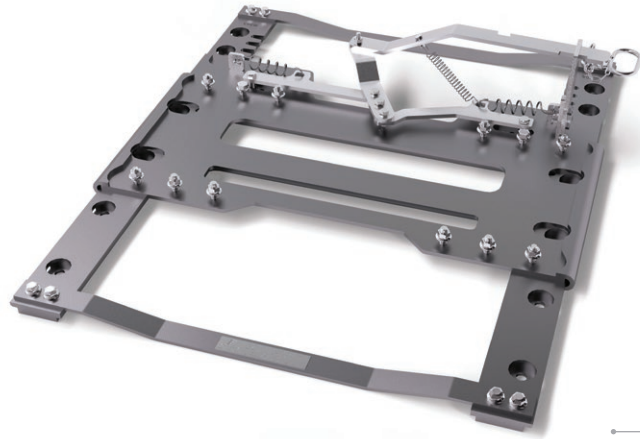

Sliding 150SF

For use with Fontaine 2" fifth wheels, our standard and medium duty slider is designed for easy positional adjustment, enabling permissible axle loads and vehicle lengths to be achieved. It is also available in two positions for increased driver safety.



Mounting plate





Supplied pre-drilled to fit all OEM chassis – our standard and medium duty fixed mounting plate is suitable for use with all Fontaine 2" fifth wheels with DIN6 feet.



Direct mount

Our lightweight fixed direct mount removes the need for OEM chassis angles and is suitable for use with standard and medium duty Fontaine 2" fifth wheels.

FONTAINE FIFTH WHEEL RANGE

RANGE	MATERIAL	USAGE	APPLICATION	IMPOSED (U) & D-VALUE T / KN	WEIGHT KG	HEIGHT OPTIONS MM (DIN 6)	LOW MAINTENANCE	SINGLE-POINT AUTOLUBE	AIR ACTIVATION	SINGLE SENSOR SAFETY CLIP	SENSOR SYSTEMS	HANDLE OPTIONS
150SP²	Pressed	Standard duty 2" on-road	 Fit for... Flexible haulage volume carriers using two and three-axle tractors.	20T / 152kN	From 113kg	138 / 148 161 / 185 210 / 230 257	×	✓	✓	✓	✓	<ul style="list-style-type: none"> Standard with safety clip Extended with safety clip Interlock
3000	Cast	Medium duty 2" on-road & limited off-road	 Fit for... Long-distance haulage with silo, tank and volume carriers using both two and three-axle tractors.	20T / 150kN	From 120kg	138 / 148 161 / 185 210 / 230 257	×	✓	✓	✓	✓	<ul style="list-style-type: none"> Standard with safety clip Extended with safety clip Interlock
3000LM	Cast	Medium duty 2" on-road & limited off-road	 Fit for... Long-distance haulage with silo, tank and volume carriers using both two and three-axle tractors.	20T / 152kN	From 120kg	138 / 148 161 / 185 210 / 230 257	✓	✓	✓	✓	✓	<ul style="list-style-type: none"> Standard with safety clip Extended with safety clip Interlock
163CI	Cast	Heavy duty 2" on & off-road	 Fit for... HGV traffic and off-road terrain.	23T / 163kN	From 140kg	148 / 161 185 / 210 230 / 257	×	✓	✓	✓	✓	<ul style="list-style-type: none"> Standard with safety clip Extended with safety clip Interlock

FONTAINE MOUNTING OPTIONS

RANGE	USAGE	APPLICATION	IMPOSED (U) & D-VALUE T / KN	WEIGHT KG	HEIGHT MM	AIR / MANUAL	SLIDE TRAVEL	150SP ²	3000	3000LM	163CI	RP59	RP90	FHD
SLIDING 150SF	Medium duty 2" on-road & limited off-road	 Fit for... Long-distance haulage with silo, tank and volume carriers using both two and three-axle tractors.	20T / 152kN	119kg	35mm	Air / Manual	Slide travel 525/750/900mm Two-position 300/525mm	✓	✓	✓	✓	✓	✓	✓
MOUNTING PLATE	Medium duty 2" on-road & limited off-road	 Fit for... Long-distance haulage with silo, tank and volume carriers using both two and three-axle tractors.	20T / 150kN	45kg / 50kg	22mm 40mm	—	—	✓	✓	✓	✓	✓	✓	✓
DIRECT MOUNT	Standard duty 2" on-road	 Fit for... Flexible haulage volume carriers using two and three-axle tractors.	20T / 150kN	40kg	140mm 160mm 200mm 230mm	—	—	✓	✓	✓	✓	×	×	×

SALES & SUPPORT

European HQ

Fontaine Fifth Wheel
Enterprise Way
Lowton WA3 2AG
United Kingdom

General enquiries

+44 (0)1942 686 000
info@fontainefifthwheel.com
sales@fontainefifthwheel.com

UK aftermarket spares

+44 (0)1942 686 001

UK fleet sales

+44 (0)7880 791 252

European sales and spares

+49 (0)1716 880 913

***FIT FOR
SAFETY
RELIABILITY
VERSATILITY
EFFICIENCY
ECONOMY
THE LONG HAUL***



FIT FOR THE LONG HAUL

Specialists in truck and trailer coupling
fontainefifthwheel.com